



HI6000 Multiparameter Modular System

HI6000-1 pH/ORP

HI6000-2 pH/ORP/ISE

HI6000-3 EC

HI6000-4 DO

Dear Customer,

Thank you for choosing a Hanna Instruments® product.

Please read this instruction manual carefully before using this instrument as it provides the necessary information for correct use of this instrument, and a precise idea of its versatility.

If you need additional technical information, do not hesitate to e-mail us at tech@hannainst.com.

Visit www.hannainst.com for more information about Hanna Instruments and our products.

All rights are reserved. Reproduction in whole or in part is prohibited without the copyright owner's written consent, Hanna Instruments Inc., Woonsocket, Rhode Island, 02895, USA. Hanna Instruments reserves the right to modify the design, construction, or appearance of its products without advance notice.

TABLE OF CONTENTS

1. Preliminary Introduction	6
1.1. Hardware Modules	6
1.2. Preconfigured Meters	7
2. Safety Measures	8
3. User Interface – Icons	9
4. General Description & Intended Use	11
4.1. Main Features	11
4.2. pH/ORP & pH/ORP/ISE Modules	12
4.3. EC Module	13
4.4. DO Module	14
5. Specifications	15
5.1. HI6000-1 pH/ORP & HI6000-2 pH/ORP/ISE Modules	15
5.2. HI6000-3 EC Module	17
5.3. HI6000-4 DO Module	19
5.4. Other Specifications	21
5.5. Electrodes	22
6. Functional & LCD Description	25
7. Getting Started	28
7.1. Installing Modules	28
7.2. Attaching the Electrode Arm	28
7.3. Connecting Keyboard, Printer, Stirrer	30
7.4. Connecting the Electrodes	31
7.5. Powering the Unit & Selecting Operating Language and Regional Preferences	32
7.6. Basic Operations	32
8. System Menu Items	33
8.1. Users	35
8.2. System Settings	38
8.3. Log Recall & Reports	45
8.4. Help	51

9. Measurement Settings	52
9.1. View	52
9.2. Alarms	54
9.3. Logging	54
9.4. Profiles	56
10. Logging	58
10.1. Automatic Logging	58
10.2. Manual Logging	59
10.3. Autohold Logging	60
11. pH Measurements	61
11.1. Measurement Settings	61
11.2. pH Calibration	67
11.3. pH Measurement	71
12. ORP Measurements	74
12.1. Measurement Settings	74
12.2. Relative mV (ORP) Calibration	78
12.3. ORP Measurement	79
13. ISE Measurements	81
13.1. Measurement Settings	81
13.2. ISE Calibration	87
13.3. ISE Measurement	91
14. EC Measurements	106
14.1. Measurement Settings	106
14.2. Conductivity Calibration	113
14.3. EC Measurement	115
15. Dissolved Oxygen Measurements	121
15.1. Measurement Settings	121
15.2. Dissolved Oxygen Calibration	127
15.3. Dissolved Oxygen Measurement	129

16. Maintenance	150
16.1. Meter	150
16.2. HI1131B pH Electrode	150
16.3. HI7662-TW Temperature Probe	151
16.4. HI7631233 EC and Resistivity Probe	151
16.5. HI7641133 OPDO [®] Probe	152
16.6. HI764833 DO Polarographic Probe	154
17. Software Update	156
18. Error Messages	157
18.1. pH, ORP, ISE	157
18.2. Conductivity	157
18.3. Dissolved Oxygen	158
18.4. Probe & Temperature Sensor	158
19. Accessories	159
Certification	163
Recommendations for Users	163
Warranty	163
Regulatory Notices for the Wi-Fi Module	164

1. PRELIMINARY INTRODUCTION

The **HI6000** is Hanna Instruments advanced meter with a large touch screen display and streamlined design.

Each **HI6000** is supplied with:

- **HI764060** electrode holder with the following accessories:
 - base plate (with integrated pivot pin) and screw, requires installation
 - cable holder clip, attached
 - electrode holder with adapter, attached
- 24 VDC power adapter
- USB-C to USB-A cable
- Instrument quality certificate
- Quick reference with QR code for manual download

Note: Save all packing material until you are sure the instrument works correctly. Any damaged or defective item must be returned in its original packing material with the supplied accessories.

Ordering information

- **HI6000-01** (US power plug)
- **HI6000-02** (EU power plug)

1.1. HARDWARE MODULES

Four hardware modules are available for the **HI6000** and up to 3 modules can be installed simultaneously.

Module	Parameter	Method-Specific Applications
HI6000-1	pH/ORP	
HI6000-2	pH/ORP/ISE	Incremental Methods for ISE applications
HI6000-3	EC	USP < 645 >
HI6000-4	Dissolved Oxygen	Oxygen Uptake Rate (OUR) Specific Oxygen Uptake Rate (SOUR) Biological Oxygen Demand (BOD)

1.2. PRECONFIGURED METERS

Preconfigured meters can be ordered at www.hannainst.com

Ordering Code	Hardware Modules & Quantities	Parameter	Supplied Electrodes
HI6222-01 (US) HI6222-02 (EU)	HI6000-2 × 2	pH/ORP/ISE	HI1131B pH electrode HI7662-TW temperature probe
HI6522-01 (US) HI6522-02 (EU)	HI6000-2 × 1 HI6000-3 × 1	pH/ORP/ISE EC	HI1131B pH electrode HI7662-TW temperature probe HI7631233 EC and resistivity probe
HI6542-01 (US) HI6542-02 (EU)	HI6000-2 × 1 HI6000-4 × 1	pH/ORP/ISE DO	HI1131B pH electrode HI7662-TW temperature probe HI7641133 opdo [®] probe
HI6542P-01 (US) HI6542P-02 (EU)	HI6000-2 × 1 HI6000-4 × 1	pH/ORP/ISE DO	HI1131B pH electrode HI7662-TW temperature probe HI764833 polarographic DO probe
HI6553-01 (US) HI6553-02 (EU)	HI6000-2 × 1 HI6000-3 × 1 HI6000-4 × 1	pH/ORP/ISE EC DO	HI1131B pH electrode HI7662-TW temperature probe HI7631233 EC and resistivity probe HI7641133 opdo [®] probe
HI6553P-01 (US) HI6553P-02 (EU)	HI6000-2 × 1 HI6000-3 × 1 HI6000-4 × 1	pH/ORP/ISE EC DO	HI1131B pH electrode HI7662-TW temperature probe HI7631233 EC and resistivity probe HI764833 polarographic DO probe

2. SAFETY MEASURES

Handling and usage precautions

The unit, while not fragile, can be damaged by improper handling and usage.

- Keep module's bay covered when module not installed.
- Transport the unit with all cables removed.
- Keep the unit on a stable and even surface, away from contact with liquid.
- Avoid excessive dirt and dust.
- Protect the unit from contact with food, oils, and chemicals.
- If the device becomes wet, gently wipe the exterior with a clean, dry cloth.
- Keep away from direct sunlight.
- Use in a safe place that is appropriate to application requirements.
- Use attachments and accessories specified in this manual only.
- Operate the capacitive touchscreen and buttons without applying pressure.
- Do not puncture the capacitive touchscreen or drop the unit.
- Do not use the device near heat sources.
- Do not place objects on top of the device.
- Do not insert objects into the ports, spaces around keys, other than the intended cable, USB drive.

Battery safety

The coin-cell battery is replaceable by a professional service center only.























WARNING









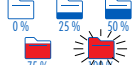















- **INGESTION HAZARD:** This product contains a button cell or coin battery.
- **DEATH** or serious injury can occur if digested.
- A swallowed button cell or coin battery can cause **Internal Chemical Burns** in as little as **2 hours**.
- **KEEP** new and used batteries **OUT OF REACH OF CHILDREN**.
- **Seek immediate medical attention** if a battery is suspected to be swallowed or inserted inside any part of the body.



- Remove and immediately recycle or dispose of used batteries according to local regulations and keep away from children.
Do NOT dispose of batteries in household trash or incinerate.
- Even used batteries may cause severe injury or death.
- Call a local poison control center for treatment information.
- Coin-cell battery type CR2032 | Nominal voltage 3.0 V
- Non-rechargeable batteries are not to be recharged.
- Do not force discharge, recharge, disassemble, heat above 85 °C (185 °F) or incinerate. Doing so may result in injury due to venting, leakage or explosion resulting in chemical burns.
- Ensure the batteries are installed correctly according to polarity (+ and -).
- Do not mix old and new batteries, different brands or types of batteries, such as alkaline, carbon-zinc, or rechargeable batteries.
- Remove and immediately recycle or dispose of batteries from equipment not used for an extended period of time according to local regulations.
- Always completely secure the battery compartment. If the battery compartment does not close securely, stop using the product, remove the batteries, and keep them away from children.

3. USER INTERFACE – ICONS

Capacitive keys	Description
	Back – return to a previous hierarchical menu level
	Home – access the measurement screen
	Menu – access the main menu
Main menu	Description
	Users – login and rights configuration & instrument accessibility
	System Settings – system configuration, module channel assignment, connectivity, stirrers, printing items
	Log Recall – access logged measurement data
	Reports – access logged data from method specific applications
	Help – access support
Measurement	Description
	Measurement Settings, accessed from measurement screen – module specific options, logging, alarms, profiles
	pH electrode
	EC and resistivity probe
	opdo [®] probe
	Polarographic DO probe
	Warning on a standby/active function
Logging	Description
	Start / stop logging (current index, displayed above and time since log start, displayed below)
	Manual logging (current index)
	Triggers log session, pending next stable measurement
	Autohold logging in progress
	Autohold applied
	Autohold, waiting stable measurement
	Annotated text / Annotated text in use
	Used storage capacity (at full capacity, the icon is displayed blinking)

Log Recall & Reports	Description
	Table view, function active/not selected
	Graph view, function active/not selected
	Information view, function active/not selected
	Report view, function active/not selected
General	Description
	Measurement profile
	Background operation in progress
	Stability/Autohold indicator
	Active buffer/standard selection during calibration Forward/backward navigation, sequence of steps (gray icon: function not available)
	pH calibration procedure, buffer selection, tutorial sequence of steps (gray icon: function not available)
	Measurement channel is not visible
	Measurement channel is locked
	Stirrer icon (alternating (inactive)/clockwise/counter clockwise)
Connectivity & Printing	Description
Ethernet	 Connection established (tap for IP address)
	 Connection in progress
	 Connection error
Wi-Fi	 Connection established (tap for IP address)
	 Connection in progress
	 Connection error
USB	 USB-A or USB-C flash drive plugged in
	 High-power consumption with the flash drive plugged in
PC	 PC connection established through USB-C port
Printer	 Printer connected - printing manual logs option enabled
	 Printer connected - printing manual logs option disabled
	 Printer not recognized or printing error

4. GENERAL DESCRIPTION & INTENDED USE

The HI6000 multiparameter modular meter is customizable to a user's laboratory measurement and applications needs.

The HI6000 allows the user to select the measurement parameters and peripheral devices needed.

Hanna Instruments® offers four different measurement modules for pH/ORP, pH/ORP/ISE, EC, and DO.

Together with appropriate sensors, the system responds to a complex range of measurement and monitoring requirements. It provides quick, reliable, and accurate measurement data that's displayed on the large touch screen, complete with a stability indicator, data log, and method-specific application reports.

The meter is supplied with an electrode holder that has a flexible arm. The holder can be mounted quickly and provides secure support for electrodes while taking measurements in sample containers.

Capacitive touch screen with multi-touch support

The meter has a 7-inch color display with resolution of 800×480 . The capacitive, multi-touch screen supports video playback and data plotting.

4.1. MAIN FEATURES

Measurement & Calibration

- Application-specific profiles allow quick and direct measurement without the need to update the sensor and system settings
- Method-specific application reports can be generated
- Measurement stability indicator (using the Stability Criteria setting)
- Temperature compensation can be Automatic (using integrated temperature sensor) or set manually
- Audible and/or alarm messages for measurements outside predefined limits
- Non-volatile memory for data storage and settings

Logging

- Active log during measurement
- Data log collection of at most 1 000 000 data points, with time and date stamp
- Logging types: manual, automatic, autohold
- Sample ID for manual and autohold data

Connectivity & Services

- Transfer logged data to a USB flash drive
- Log files include measurements and calibration data (as .CSV file)
- FTP and email for log export via Ethernet and Wi-Fi connection
- Download logs using the meter's embedded web server
- USB type A for USB drive, printer (standard or thermal), and keyboard
- USB type C for USB drive and PC connection

User-Support Feature

- Help section — brief overview of instrument's main functionalities and features

4.2. pH/ORP & pH/ORP/ISE MODULES

The [HI6000-1](#) and [HI6000-2](#) modules enable pH measurement when used with the [HI1131B](#) pH electrode and [HI7662-TW](#) temperature probe.

A separate ORP sensor is required for ORP measurements.

[HI1131B](#) is a glass body, double junction, refillable pH electrode with an indicating sensor made of high temperature (HT) glass. The double junction reference and HT glass design allow the electrode to be used in a wide variety of applications.

Probe connection to the unit is secured through a galvanically isolated BNC connection.

Note: *HI6000 meter works with all Hanna Instruments® pH electrodes with BNC connector.*

[HI7662-TW](#) temperature probe allows the meter to perform automatic temperature compensation (ATC).

[HI6000-2](#) module supports measurement with Ion Selective Electrodes (ISE). Direct measurement and incremental methods are available.

Known Addition, Known Subtraction, Analyte Addition, and Analyte Subtraction incremental methods are versatile methods for the measurement of ions in aqueous samples from environmental, agricultural, and industrial, to biotechnical, pharmaceutical, food, wastewater, and drinking water. These methods are great for complex or high ionic strength samples as the electrodes remain immersed throughout the process, making analysis faster and more accurate.

Choice of Measurement Unit

- **pH**
 - pH, mV
- **ORP**
 - mV, Rel.mV
- **ISE**
 - ppt, ppm, ppb, g/L, mg/L, $\mu\text{g/L}$, mg/mL, $\mu\text{g/mL}$, M, mol/L, mmol/L, %w/v, user defined

Calibration

- pH calibration using
 - up to five Hanna Instruments pH buffers (pH 1.68, 3.00, 4.01, 6.86, 7.01, 9.18, 10.01 and 12.45)
 - up to five custom buffers
- mV calibration using a single point to calibrate offset.
- ISE calibration using up to five nominal standard values (e.g. for ppm: 0.010, 0.100, 1.00, 10.0, 100, 1000, 10000 ppm) and/or up to five custom solutions (user supplied)

4.3. EC MODULE

The HI6000-3 module enables conductivity measurements when used with the HI7631233 platinum four-ring probe. Direct measurement and USP < 645 > for bulk water analysis are available.

The HI7631233 integrated temperature sensor adjusts the measured conductivity to a reference temperature by applying compensation algorithms.

The electrolytic conductivity (EC) reading from the HI7631233 sensor can be used to calculate Total Dissolved Solids (TDS), Resistivity, and Salinity (PSU, ppt, or %).

- **TDS** is a calculated value based on the conductivity of the solution ($TDS = \text{factor} \times EC_{25}$).
A TDS factor is a conversion factor used to change an EC measurement to a ppm (or ppt) measurement.
- **Salinity (PSU)** relates the ratio of electrical conductivity of a normal seawater sample at 15 °C and 1 atmosphere to a potassium chloride solution (KCl) with a mass of 32.4356 g/Kg water at the same temperature and pressure. Under these conditions the ratio is equal to 1 and $S=35$.
The practical salinity scale may be applied to values 0 through 42.00 psu at temperatures between 0 to 35 °C.
- **Salinity (ppt)** measurements are based on the 0.00 to 80.00 g/L Natural Seawater Scale from 10 to 31 °C. It determines the salinity based upon a conductivity ratio of sample to standard seawater at 15 °C and an approximate salinity value of 35 in seawater.
- **Salinity (%)** in this scale 100% salinity is equivalent to roughly 10% solids.

Choice of Measurement Unit

- **Conductivity**
 - $\mu S/cm$, mS/cm
- **Resistivity**
 - $\Omega \cdot cm$, $k\Omega \cdot cm$, $M\Omega \cdot cm$
- **TDS**
 - ppm, ppt
- **Salinity**
 - ppt, PSU, %

Calibration

- Conductivity calibration using:
 - up to four Hanna Instruments standards — 84 $\mu S/cm$, 1413 $\mu S/cm$, 5000 $\mu S/cm$, 12880 $\mu S/cm$, 80000 $\mu S/cm$ and 111800 $\mu S/cm$ — for cell factor determination; and 0 $\mu S/cm$ for Offset
 - up to four custom standards
- Salinity (%) calibration using 100% salinity standard

4.4. DO MODULE

The [HI6000-4](#) module enables dissolved oxygen measurements when used with the [HI7641133](#) optical dissolved oxygen (opdo[®]) probe or the [HI764833](#) polarographic dissolved oxygen probe.

Direct measurement, Oxygen Uptake Rate (OUR), Specific Oxygen Uptake Rate (SOUR), and Biological Oxygen Demand (BOD) are available.

The OUR, SOUR, BOD methods guide the user through the procedures adhering to the standard method guidelines. Concentration measurements are automatically compensated for barometric pressure, temperature, and salinity.

- OUR measurements determine the biological activity of a system in terms of oxygen consumption or respiration rate.
- SOUR measurements determine the oxygen consumption of a system.
- BOD measurements determine the oxygen uptake rate by microorganisms in a water sample over a period time.

[HI7641133](#) opdo probe (with [HI764113-1](#) Smart Cap) provides accurate dissolved oxygen measurements over long periods of time reducing the need for frequent calibration. The Cap, pre-loaded with calibration coefficients, includes the immobilized O₂ sensitive luminophore with a rugged, insoluble black oxygen permeable protective layer.

The principle of operation is based on the principle of fluorescence quenching and features an immobilized Pt-based luminophore that is excited by the light of a blue LED and emits a red light. Dissolved oxygen quenches this excitation. When there is no oxygen present, the lifetime of the signal is the greatest; as oxygen hits the sensing surface, the lifetime becomes shorter.

The intensity and lifetime are inversely proportional to the amount of oxygen present; as oxygen interacts with the luminophore it reduces the intensity and lifetime of the luminescence. The lifetime of the luminescence is measured by a photodetector, and is used to calculate the dissolved oxygen concentration. This is, in turn, reported by the meter as % saturation or mg/L of dissolved oxygen.

[HI764833](#) Clark-Type polarographic probe features a platinum cathode and Ag/AgCl anode assembly and a built-in temperature sensor. The temperature measurement is used in computations for dissolved oxygen measurements.

The probe has a thin, 12 mm (0.47"), design that allows for convenient measurement in narrow vessels such as test tubes, wine bottles, standard BOD bottles.

The probe is fitted with a PTFE screw cap membrane that separates the probe's cathode and anode from the sample being measured. Oxygen diffuses across the membrane and interacts with the polarographic system to produce a current proportional to oxygen concentration. The cap is filled with [HI7041](#) electrolyte and screwed on to the probe. Screw-on caps with pretensioned membranes provide quick maintenance.

Choice of Measurement Unit

- DO — %Sat, mg/L, ppm
- BOD — ppm, mg/L
- OUR — ppm, mg/L
- SOUR — ppm, mg/L
- Pressure — mmHg, mbar, kPa, inHg, psi, atm

Calibration

- One or two points automatic calibration at 100.0 % (8.26 mg/L) and 0.0 % (0.00 mg/L)
- One point manual calibration using a valued entered by the user

5. SPECIFICATIONS

5.1. HI6000-1 pH/ORP & HI6000-2 pH/ORP/ISE MODULES

pH	Range *	-2.0 to 20.0 pH -2.00 to 20.00 pH -2.000 to 20.000 pH
	Resolution	0.1 pH 0.01 pH 0.001 pH
	Accuracy	±0.1 pH ±0.01 pH ±0.002 pH (±1 last significant digit)
	Temperature compensation	Automatic Manual
	Calibration points	Up to 5
	Calibration type	Automatic Semiautomatic Manual
	Standard buffers	Hanna and NIST (pH 1.68, 3.00, 4.01, 6.86, 7.01, 9.18, 10.01, 12.45)
	Custom buffers	Up to 5
	Custom group	Option to select from eight standard buffers and user-defined custom buffers
	1 st calib. point	Offset or Point (user setting)
	Isopotential point	-2.000 to 20.000 pH
mV	Range	-2000.0 to 2000.0 mV
	Resolution	1 mV 0.1 mV
	Accuracy	±0.2 mV ±1 last significant digit
	Calibration	Single point offset, ±2000.0 mV

* The range may be limited by the probe's limits.

ISE (HI6000-2 only)	Range*	1.0×10^{-5} to 300.0 ppt (g/L or mg/mL) 5.0×10^{-3} to 1.0×10^5 ppm (mg/L or $\mu\text{g/mL}$) 1.0 to 5.0×10^7 ppb ($\mu\text{g/L}$) 1.0×10^{-7} to 10.0 M (mol/L) 1.0×10^{-4} to 1.0×10^4 mmol/L 1.0×10^{-6} to 60.0 %w/v 5.0×10^{-7} to 5.0×10^7 user
	Resolution	1, 2, 3 significant digits
	Accuracy	$\pm 0.5\%$ (monovalent ions) $\pm 1\%$ (divalent ions)
	Calibration points	Up to 5
	Calibration type	All standards Standard group
	Standards	7 standard solutions available for each concentration unit
	Custom standards	Up to 5
	Custom group	Up to 5
Temperature	Range *	-20.0 to 120.0 °C -4.0 to 248.0 °F 253.2 to 393.2 K
	Resolution	0.1 °C 0.1 °F 0.1 K
	Accuracy	± 0.2 °C ± 0.4 °F ± 0.2 K
	Calibration	Single point, adjustable
	Reading mode	Direct Direct/Autohold ISE only <ul style="list-style-type: none"> ◦ Known Addition ◦ Known Subtraction ◦ Analyte Addition ◦ Analyte Subtraction

* The range may be limited by the probe's limits.

View	Basic	Measurement data Measurement profile (if enabled) Stability status
	Simple GLP	Basic view information Last calibration date, slope, offset (pH, Rel. mV - ISE only)
	Full GLP	Simple GLP information Calibration point details (pH & ISE)
	Graph	Basic view information Measurement versus time graph
	Table	Basic view information Table with measurements updated every second

5.2. HI6000-3 EC MODULE

Conductivity	Range *	0.000 to 9.999 $\mu\text{S}/\text{cm}$ 10.00 to 99.99 $\mu\text{S}/\text{cm}$ 100.0 to 999.9 $\mu\text{S}/\text{cm}$	1.000 to 9.999 mS/cm 10.00 to 99.99 mS/cm 100.0 to 1000.0 mS/cm
	Resolution	0.001 $\mu\text{S}/\text{cm}$ 0.01 $\mu\text{S}/\text{cm}$ 0.1 $\mu\text{S}/\text{cm}$	0.001 mS/cm 0.01 mS/cm 0.1 mS/cm
	Accuracy	$\pm 1\%$ of reading or $\pm 0.010 \mu\text{S}/\text{cm}$, whichever is greater	
	Cell constant	0.0500 to 200.0000 /cm	
	Calibration type	Automatic Manual	
	Calibration points	Single Up to 5	
	Calibration solutions	84 $\mu\text{S}/\text{cm}$ 1413 $\mu\text{S}/\text{cm}$ 5000 $\mu\text{S}/\text{cm}$	12880 $\mu\text{S}/\text{cm}$ 80000 $\mu\text{S}/\text{cm}$ 111800 $\mu\text{S}/\text{cm}$
	Temperature compensation	Linear Natural Standard Disabled	
	Reference temperature	5.0 to 30.0 $^{\circ}\text{C}$ (41.0 to 86.0 $^{\circ}\text{F}$, 278.2 to 303.2 K)	
	Temperature coefficient	0.00 to 10.00 $\%/^{\circ}\text{C}$	

* The range may be limited by the probe's limits.

Resistivity	Range	1.0 to 99.9 $\Omega \cdot \text{cm}$ 100 to 999 $\Omega \cdot \text{cm}$	1.00 to 9.99 $\text{K}\Omega \cdot \text{cm}$ 10.0 to 99.9 $\text{K}\Omega \cdot \text{cm}$ 100 to 999 $\text{K}\Omega \cdot \text{cm}$	1.00 to 9.99 $\text{M}\Omega \cdot \text{cm}$ 10.0 to 100.0 $\text{M}\Omega \cdot \text{cm}$
	Resolution	0.1 $\Omega \cdot \text{cm}$ 1 $\Omega \cdot \text{cm}$	0.01 $\text{K}\Omega \cdot \text{cm}$ 0.1 $\text{K}\Omega \cdot \text{cm}$ 1 $\text{K}\Omega \cdot \text{cm}$	0.01 $\text{M}\Omega \cdot \text{cm}$ 0.1 $\text{M}\Omega \cdot \text{cm}$
	Accuracy	$\pm 1\%$ of reading or $\pm 1 \Omega \cdot \text{cm}$, whichever is greater		
Total Dissolved Solids (TDS)	Range	0.000 to 9.999 ppm 10.00 to 99.99 ppm 100.0 to 999.9 ppm	1.000 to 9.999 ppt 10.00 to 99.99 ppt 100.0 to 400.0 ppt actual TDS (with 1.00 factor)	
	Resolution	0.001 ppm 0.01 ppm 0.1 ppm	0.001 ppt 0.01 ppt 0.1 ppt	
	Accuracy	$\pm 1\%$ of reading or ± 0.01 ppm, whichever is greater		
Salinity	Range	0.00 to 42.00 PSU (Practical Salinity Scale) 0.00 to 80.00 ppt (Natural Sea Water) 0.0 to 400.0 % (Percent Scale)		
	Resolution	0.01 PSU 0.01 ppt 0.1 %		
	Accuracy	$\pm 1\%$ of reading		
	Calibration	1 point, using 100 % salinity calibration solution (% scale only)		
Temperature	Range *	-20.0 to 120.0 $^{\circ}\text{C}$ -4.0 to 248.0 $^{\circ}\text{F}$ 253.2 to 393.2 K		
	Resolution	0.1 $^{\circ}\text{C}$ 0.1 $^{\circ}\text{F}$ 0.1 K		
	Accuracy	± 0.2 $^{\circ}\text{C}$ ± 0.4 $^{\circ}\text{F}$ ± 0.2 K		
	Calibration	Single point, adjustable		
Reading mode	Direct Direct/Autohold Direct/USP (Conductivity only)			

* The range may be limited by the probe's limits.

View	Basic	Measurement data Measurement profile (if enabled) Stability status
	Simple GLP	Basic view information Last calibration date and offset
	Full GLP	Simple GLP information Calibration point details (conductivity & salinity)
	Graph	Basic view information Measurement versus time graph
	Table	Basic view information Table with measurements updated every second

5.3. HI6000-4 DO MODULE

DO	Range *	0.0 to 500.0 % saturation 0.00 to 90.00 mg/L (ppm) concentration	
	Resolution	0.1 % saturation 0.01 mg/L (ppm)	
	Accuracy	Refer to probe used	
	Calibration points	One or two points at 100.0 % (8.26 mg/L) and 0.0 % (0.00 mg/L)	
	Calibration type	Automatic Manual (user entered value in % saturation, mg/L, or ppm)	
Barometric pressure	Range	450.0 to 850.0 mmHg 600.0 to 1133.2 mbar 60.00 to 113.32 kPa	17.72 to 33.46 inHg 8.702 to 16.436 psi 0.5921 to 1.1184 atm
	Resolution	0.1 mmHg 0.1 mBar 0.01 kPa	0.01 inHg 0.001 psi 0.0001 atm
	Accuracy	± 3 mmHg within ± 15 % from calibration point ± 3 mmHg ± 1 least significant digit	
	Compensation	Automatic (meter-integrated barometer) Manual	

* The range may be limited by the probe's limits.

Temperature	Range *	— 20.0 to 120.0 °C — 4.0 to 248.0 °F 253.2 to 393.2 K
	Resolution	0.1 °C 0.1 °F 0.1 K
	Accuracy	Refer to probe used
	Compensation	Automatic Manual
	Calibration	Single point, adjustable
Salinity compensation	Manual > 0.00 to 45.00 PSU or ppt > 0.0 to 130.0 ‰	
Reading mode	Direct Direct/Autohold OUR SOUR BOD	
View	Basic	Measurement data Measurement profile (if enabled) Stability status
	Simple GLP	Basic view information DO last calibration date, offset, average slope
	Full GLP	Simple GLP information Calibration point details
	Graph	Basic view information Measurement versus time graph
	Table	Basic view information Table with measurements updated every second

* The range may be limited by the probe's limits.

5.4. OTHER SPECIFICATIONS

Reading	Stability criteria	Accurate Medium Fast
	Sampling Rate	1000 ms
Logging	Type	Automatic Manual Autohold
	Number of records	50 000 maximum per file Stores at least 1 000 000 data points per user
	Automatic interval	1, 2, 5, 10, 30 seconds 1, 2, 5, 10, 15, 30, 60, 120, 150, 180 minutes
	Sample ID	Incremental mode Manual
	Export option	.CSV file format
Connectivity	USB-A	2 ports › keyboard and/or printer input › USB flash drive
	USB-C	1 port › PC connectivity and USB-C type flash drive
	Wi-Fi & Ethernet	FTP Web server Log transfer and download Email
	RS232	Connecting peripherals
Calibration reminder	Daily › 0 minutes to 23 hours 59 minutes Periodic › 1 minute to 30 days, 23 hours and 59 minutes Disabled	
Users	Up to 9 users and the default administrator account	
Power supply	DC adapter 100-240 VAC to 24 VDC 2A	
Environment	0 to 50 °C / 32 to 122 °F / 273 to 323 K maximum 95 % RH non-condensing	
Dimensions	205 x 160 x 77 mm (8.0 x 6.2 x 3.0 ")	
Weight	Approximately 1.2 kg (2.65 lbs.)	

5.5. ELECTRODES

HI1131B pH electrode

Range	0 to 13 pH
Reference cell type	Double, Ag/AgCl
Junction type	Ceramic Single 15-20 μ L per h
Refill electrolyte	3.5M KCl
Maximum pressure	0.1 bar
Body material	Glass
Tip shape	Spheric (\emptyset 9.5 mm)
Operating temperature	-5 to 100 °C (23 to 212°F) High Temperature (HT)
Cable	Coaxial; 1 m (3.3')
Recommended use	Laboratory samples, general purpose

HI7662-TW Temperature probe

Range	-5 to 105 °C (23.0 to 221.0°F)
Body material	Stainless steel
Connector type	RCA Phono connector
Dimensions	Total length: 100 mm (3.94 ") Active part: \emptyset 3 mm (0.12 ")
Cable	1 m (3.3')

HI7631233 Conductivity probe

Range	0 to 1000 mS/cm	
Recommended operating temperature	-5 to 100 °C (23 to 212 °F)	
Temperature sensor	Built-in	
Cell constant	1 \pm 15 %	
Cell type	Four-ring, platinum on glass	
Body	Polyetherimide (PEI)	
Wetted parts	Sensor body	PVDF
	O-ring	NBR
Sensor diameter	\emptyset 12.0 mm	
Connection	DIN	
Cable length	1 m (3.3')	

HI7641133 Optical DO probe

Dissolved Oxygen	Range	0.0 to 500.0 % saturation 0.00 to 90.00 mg/L (ppm) concentration
	Resolution	0.1 % saturation 0.01 mg/L (ppm)
	Accuracy	± 1.5 % of reading ± 0.01 mg/L (ppm) for 0.00 to 20.00 mg/L (ppm) ± 5 % of reading for 20.00 to 50.00 mg/L (ppm) ± 1.5 % of reading ± 0.1 % for 0.0 to 200.0 % saturation ± 5 % of reading for 200.0 to 500.0 % saturation
Temperature	Range	-5.0 to 50.0 °C 23.0 to 122.0 °F 268.2 to 323.2 K
	Resolution	0.1 °C 0.1 °F 0.1 K
	Accuracy	± 0.3 °C ± 0.4 °F ± 0.2 K
Sensor type	Optical	
Wetted parts	Body material	ABS
	Smart Cap	Polypropylene + PMMA (dome-shaped membrane)
	O-ring	NBR
	Temperature contact	Stainless steel
Cable	1 m (3.3') PVC jacket	
Dimensions	$\varnothing 17$ mm (0.67")	

HI764833 Polarographic DO probe

Dissolved Oxygen	Range	0.0 to 300.0 % saturation 0.00 to 45.00 mg/L (ppm) concentration
	Resolution	0.1 % saturation 0.01 mg/L (ppm)
	Accuracy	± 1.5 % of reading ± 1 least significant digit
Temperature	Range	0.0 to 50.0 °C 32.0 to 122.0 °F 273.2 to 323.2 K
	Resolution	0.1 °C 0.1 °F 0.1 K
	Accuracy	± 0.2 °C ± 0.4 ° ± 0.2 K
Sensor type	Polarographic	
Wetted parts	Body material	PEI
	Membrane cap	PEI + PTFE membrane
	O-ring	NBR
	Temperature contact	Stainless steel
Cable	1 m (3.3') PVC jacket	
Dimensions	Ø 12 mm (0.47")	

6. FUNCTIONAL & LCD DESCRIPTION

Front View

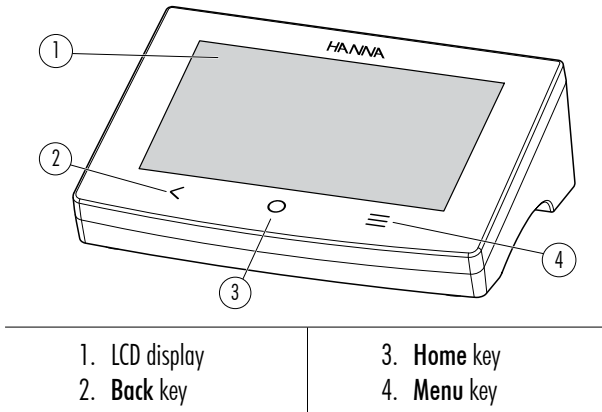

LCD Description

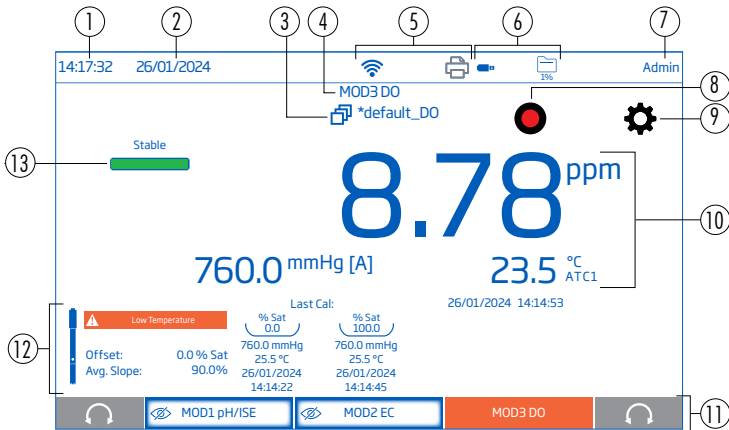

1. Current time 2. Current date 3. Measurement profile 4. Hardware module 5. Connectivity and Printer icons 6. USB connection status Used logging space 7. User name (default "Admin")	8. Start logging icon 9. Measurement settings icon 10. Measurement includes temperature and compensation status 11. Bottom status area 12. Calibration information 13. Stability indicator
---	---

Direct Keys

Icon	Name	Function
	Back	<ul style="list-style-type: none"> returns user to previous hierarchical menu level exit or escape function
	Home	<ul style="list-style-type: none"> access to measurement screen exit or escape function
	Menu	<ul style="list-style-type: none"> access to Users, System Settings, Log Recall, Reports, Help

Top Status Area

Continuously displayed after powering the unit, the status area runs horizontally across the top of the LCD screen.



1. Current time and date
2. Network and device connectivity
3. Background operation in progress
4. Used storage capacity
5. User name

Tap on the status icons to view network details () and used storage space (, 0%).



Bottom Status Area

Displays stirrer controls () and hardware module configuration (1, 2, 3) with status indicators.

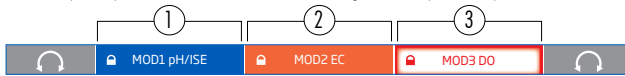

Stirrer

When a stirrer is connected, the icon is used to turn it on and off.

The stirrer speed is set in the system menu and the rotation (clockwise, counter clockwise, or alternating) is set in the system settings.

Module Indicators

Module is visible on the display			
Module is not visible on the display			
Alarm has been triggered on the module			
Out of range warning has been triggered on the module			
Module configuration is locked			
Logging is in-progress on module			

Rear View

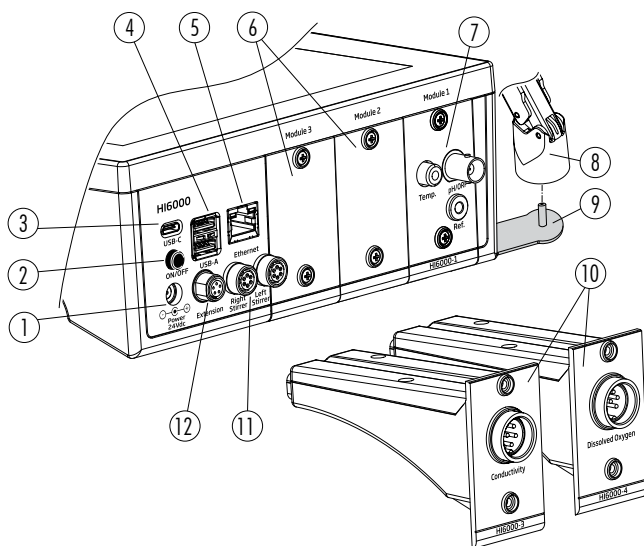

- | | |
|---|-------------------------------------|
| 1. Input for power cable | 7. Module bay with module installed |
| 2. Power button | 8. Electrode holder |
| 3. Input for USB-C flash drive or PC cable | 9. Electrode holder plate |
| 4. Input for USB-A flash drive (x2) or keyboard/printer | 10. Uninstalled hardware modules |
| 5. Ethernet port | 11. Right / Left stirrer port |
| 6. Empty module bay with cover installed | 12. Peripherals port |

7. GETTING STARTED

7.1. INSTALLING MODULES

- With device disconnected from power, remove the two screws (1) and set aside.
- Unpack the module. Insert the module into the module bay (2).
- The module is seated correctly when the latching mechanism is locked into the housing.
- Use the two screws (1) to secure the module in place.

Note: Use the blank cover to keep empty module bay's protected.

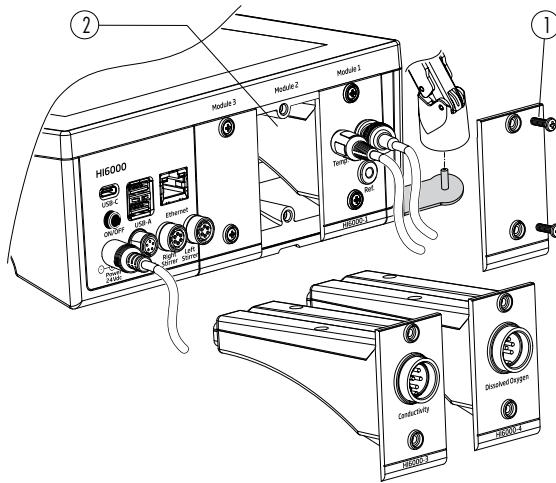

7.2. ATTACHING THE ELECTRODE ARM

Attaching the Electrode Holder Base Plate

- Take the [HI764060](#) electrode arm from the box.
 - Identify the metal base plate (4) with the integrated pivot pin (5) and the screw (2).
 - The plate may be attached to either side of the meter, left (L) or right (R).
 - Place the meter face down on a clean, dry surface.
 - Align the hole on the base plate (3) over the rubber foot (6R or 6L).
- The pivot pin (5) should be facing downward.

- Use a screwdriver (1) to tighten the screw (2) and attach the base plate (3) to the meter (4).

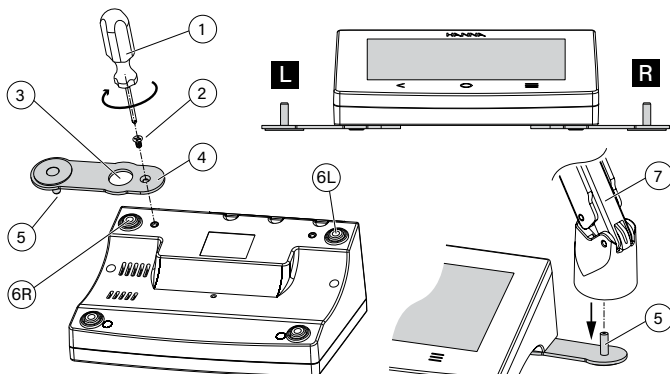

- Position the meter with the display facing up.
- Slide electrode holder (7) over the pivot pin (5).
A “slide in” motion is required to lock the arm into position.
- For increased arm rigidity, tighten the metal knobs on both sides of the electrode arm.

Cable holder clip

The electrode holder is delivered with a cable holder clip (attached) that secures several cables whilst allowing them to move freely with the arm motion.

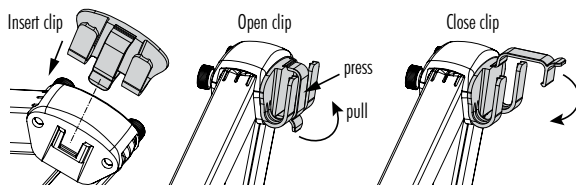

1. To open the latch, press the clip inward while pulling up the latch.
2. To close the latch, lower latch over cable and snap closed.

The latch snaps in position and secures the cables inside.

Reattach the cable holder clip onto the electrode arm:

1. Align the clip's dovetail over the slot.
2. Gently push down to slide in position.

Using the Adapter

The electrode arm ends with an electrode holder fitted with an adapter with three different-sized apertures:

- center-front (temperature probe only)
- center-back (with center positioning or optical probe adapter)
- left and right (pH, ORP, ISE, EC, or polarographic DO probe)

Optical Probe Adapter

1. Squeeze to depress the two locking wings. Push the adapter up to remove the center positioning adapter.
2. Align the flat surface on the probe with the snap fit guides on the adapter.
3. With the flat side of the optical probe adapter upwards, push the probe in to the adapter.
4. Insert the adapter (and probe) slowly into the electrode holder, keeping the positioning marks on the adapter and holder aligned with each other.
5. Push (light to moderate pressure) the adapter down until it securely clicks in place.
6. Clip the cables through the top-entry cable clip.

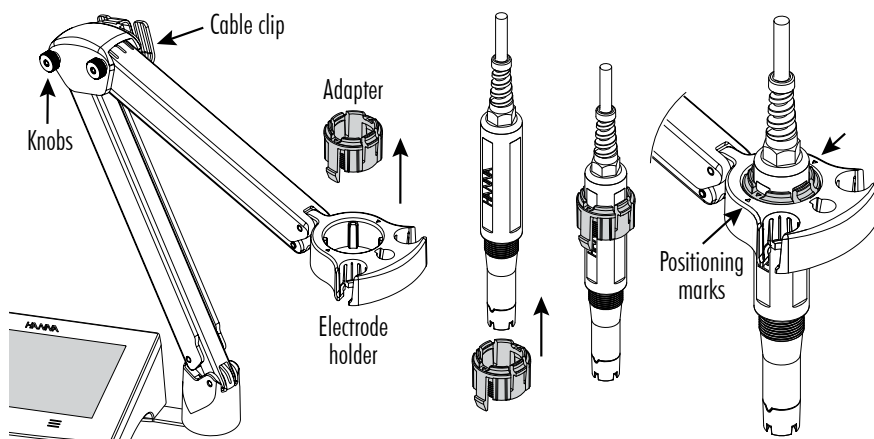

Notes: Do not use excessive force to insert the adapter. If there is resistance, re-check that the positioning marks are correctly aligned.

7.3. CONNECTING KEYBOARD, PRINTER, STIRRER

Connecting a USB-A keyboard

Connect a USB's keyboard plug into the USB-A input on the back of the unit. Once connected the keyboard is automatically detected.

Use the keyboard to input user details, type passwords and enter sample information.

Connecting a Printer

Hanna[®] aims to ensure meter compatibility with USB printers but cannot ensure compatibility with all models. HI6000 can print directly to certain models of USB-dedicated printers with PCL printer language capability.

Printer components and requirements

- Printer, PCL driver compatible
- Power cable
- USB connector cable with two ends:
 - › type B connector (plugs into printer)
 - › type A connector (plugs into the USB port on the meter)

Connecting the Stirrer

Connect the cable for the stirrer to one of the connector's sockets (marked Left or Right) on the meter's rear panel. The stirrer is automatically detected.

7.4. CONNECTING THE ELECTRODES

HI6000-1 pH/ ORP & HI6000-2 pH/ORP/ISE

Electrode Compatibility

- Analog pH, ORP, or ISE electrode with BNC connector (non-amplified or non-digital)
 - pH, ORP, or ISE half-cell sensors and separate reference electrodes with suitable jack connectors
 - Hanna Instruments pH electrodes with integrated temperature sensor
- See [19. Accessories](#) section.

Note: Always turn the meter off before connecting the electrode/probe!

pH, ORP, and ISE electrodes attach to the meter through a BNC connector, which makes attaching and removing the probe an easy process. When connected, the probe is automatically detected.

- Connect the probe to the BNC connection port.
- Align the key and twist the plug into the socket.
- Half-cell electrodes:
Connect a reference half-cell electrode to the socket labeled "Ref."
A banana connector is required for a separate reference.
- Place the probe into the holder and secure the cable.

The temperature probe attaches to the meter through a RCA connector.

- Plug the connector into the socket.
- Place the probe into the holder and secure the cable.

HI6000-3 EC

The HI7631233 probe is connected to the meter through a DIN connector, which makes attaching and removing the probe an easy process.

- Connect the probe to the DIN connection port on the back of the meter.
- Align the pins and key, then push the plug into the socket.
- Place the probe into the holder and secure the cable in the cable holder clip.

Note: Connector must be connected firmly for the system to work correctly!

HI6000-4 DO

The HI7641133 probe is connected to the meter through a DIN connector, which makes attaching and removing the probe an easy process. When connected, the probe is automatically detected.

- Connect the probe to the DIN connection port on the back of the meter.
- Align the pins and key, then push the plug into the socket.
- Place the probe into the holder and secure the cable in the cable holder clip.

Note: Connector must be connected firmly for the system to work correctly!

7.5. POWERING THE UNIT & SELECTING OPERATING LANGUAGE AND REGIONAL PREFERENCES



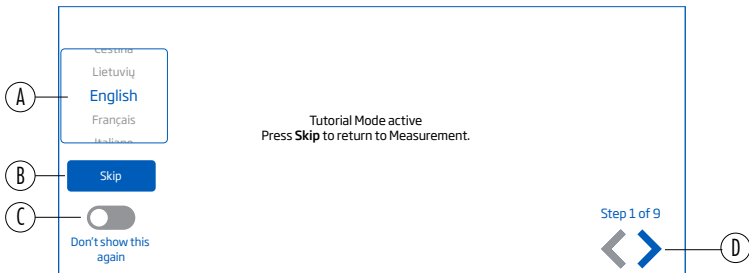
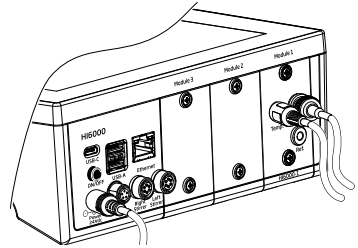





1. Connect the power adapter to the rear panel of the meter.
2. Connect the power plug into the 24 V power socket.
3. Press the black ON/OFF power button.
At start up, the meter briefly displays the initialization screen.
4. The instrument launches into a startup tutorial.
By default English is selected.
Use the language window (A) to select the operating language.
5. Use the left and right arrow keys (D) to view the startup tutorial.
Alternatively tap  (B) to return to measurement.
By default the user is logged in as an administrator.
See section 8.1. [Users](#) for a more detailed description.
6. Use the slider icon (C) to disable the start up tutorial.



Note: Remove the transparent film that protects the capacitive touchscreen prior to operating the meter.

7.6. BASIC OPERATIONS

General operating modes are setup, measurement, logging, and data sharing.





- Tap  key (**Menu**) to access:
 -  User settings
 -  System settings
 -  Log recall files and file management.
User can view a single sample or an interval log session.
 -  Reports for method specific applications
 -  Help for text and video support
- Tap  key (**Home**) to return to measurement.
- Tap  icon (**Measurement Settings**) to access sensor-related functions.

8. SYSTEM MENU ITEMS

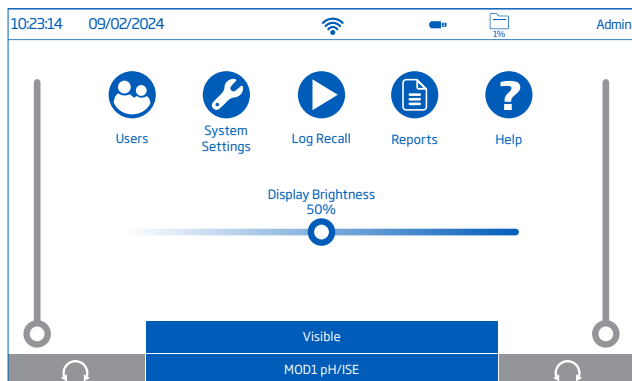
Tap  key (**Menu**) to access System Menu screen.

Note: In order to access the system menu a user must be logged in.



Symbol	Name	Functionality
	Users	Login and rights configuration Instrument accessibility
	System Settings	System configuration, connectivity, and printing items
	Log Recall	Access logged measurement data
	Reports	Access method-specific application reports
	Help	Access video-supported outline of main instrument functionalities

Brightness Control Bar



Drag the slider along the control bar to adjust brightness.

Stirrer Speed Control Bar

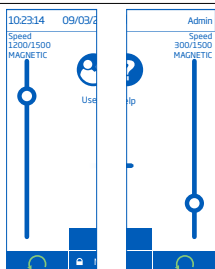

The stirrer speed and type are displayed.
Drag the slider along the control bar to change the speed of the stirrer.

Measurement Screen Configuration

Up to three hardware modules can be viewed on the measurement screen at one time.

On the measurement screen, the bottom status bar is used to quickly change the visible module.

Note: When three hardware modules are visible, only basic and simple GLP views are available.

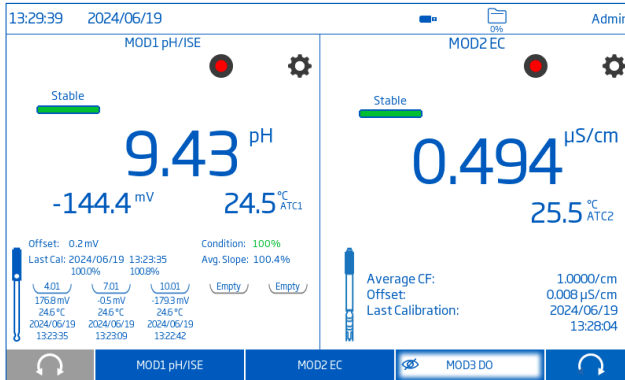
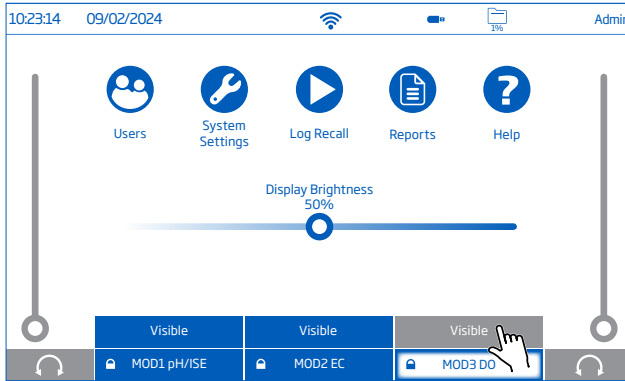

Module is visible

Module is not visible

8.1. USERS

Users is the first item under the System Menu and enables logins and account creation.

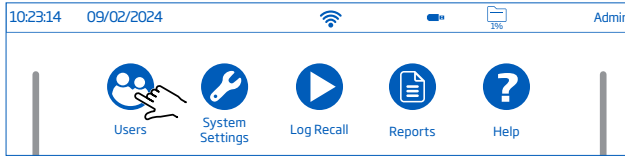

On first access, “Admin” is used as default user name and no password is required. Default options are updated from the Users menu.

Function	Administrator Rights*	Standard User
Enable account creation	✓	–
Reset password	✓	–
Delete account	✓	–
Factory settings reset	✓	–
Customize settings	✓	✓
Add FTP information	✓	–
Change password	✓	✓
View and delete log files	✓	✓

Account Management

1. Log in to the Administrator account.
2. Tap **Edit Users** to enter the Account Management screen.

The administrator can:

- Enable Account Creation
- Enable Logins
- Reset password for user accounts
- Delete user accounts

Each power up requires user selection before the instrument enters measurement mode.

Log in & Create New Account

1. Tap ☰ followed by 😊.
2. Tap **Edit Users** to enter Account Management.

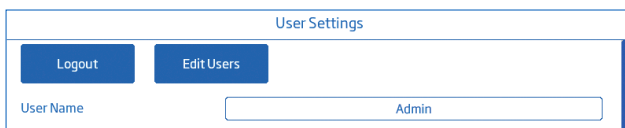

3. Tap  to enable Account Creation and Logins. Tap  to return.



4. Tap **Logout** to enter Users screen. “Admin” account is automatically created.

5. Tap the **plus** symbol avatar.

6. Input user name and tap .

7. Enter password and tap .

To bypass the password function, leave the field empty and tap  on this screen.

Reenter password to confirm.

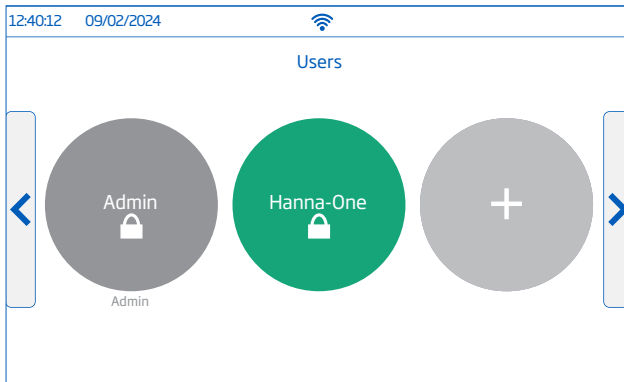

Configure User Settings

Name, Password, Icon Color, Full Name, Information Fields, FTP-dedicated fields, Email Address

- To edit option, tap field and use the on-screen keypad to input information.
- Use the FTP dedicated fields and email address for file transfer of logged data.

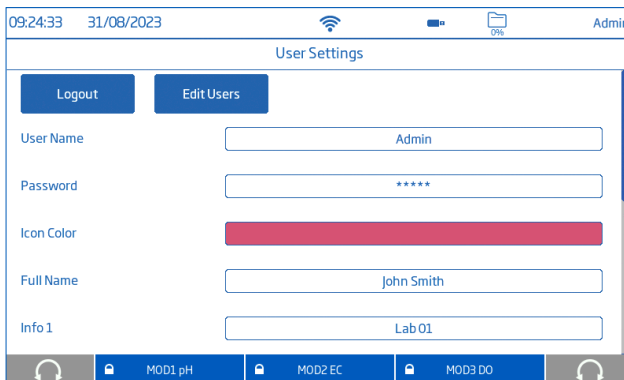

Log Out & Switch User

1. Tap  followed by **Logout**.
2. Tap on user's account avatar.
3. Input password (if enabled).

Reset Password

1. Select user name from users list.
2. Tap **Reset Password**.

The password is removed. User will be prompted to enter a new password when selected from the log-in screen.

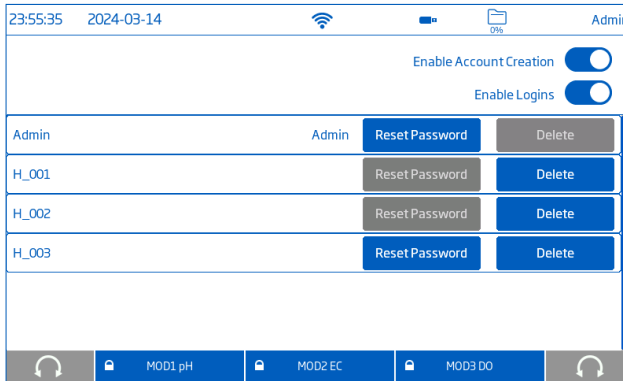

Delete Users

Select user name and tap **Delete**. The instrument prompts for confirmation.

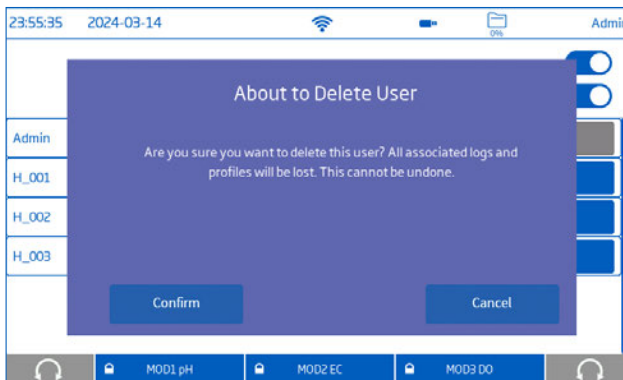

8.2. SYSTEM SETTINGS

System Settings is the second item under the System Menu.

Channels, Network, Connect & Print, Stirrers, System, Info tabs permit users to navigate channel settings, system settings and operations, configure network connection and architecture, connectivity and printing services, stirrer settings, change system settings, and view meter information.

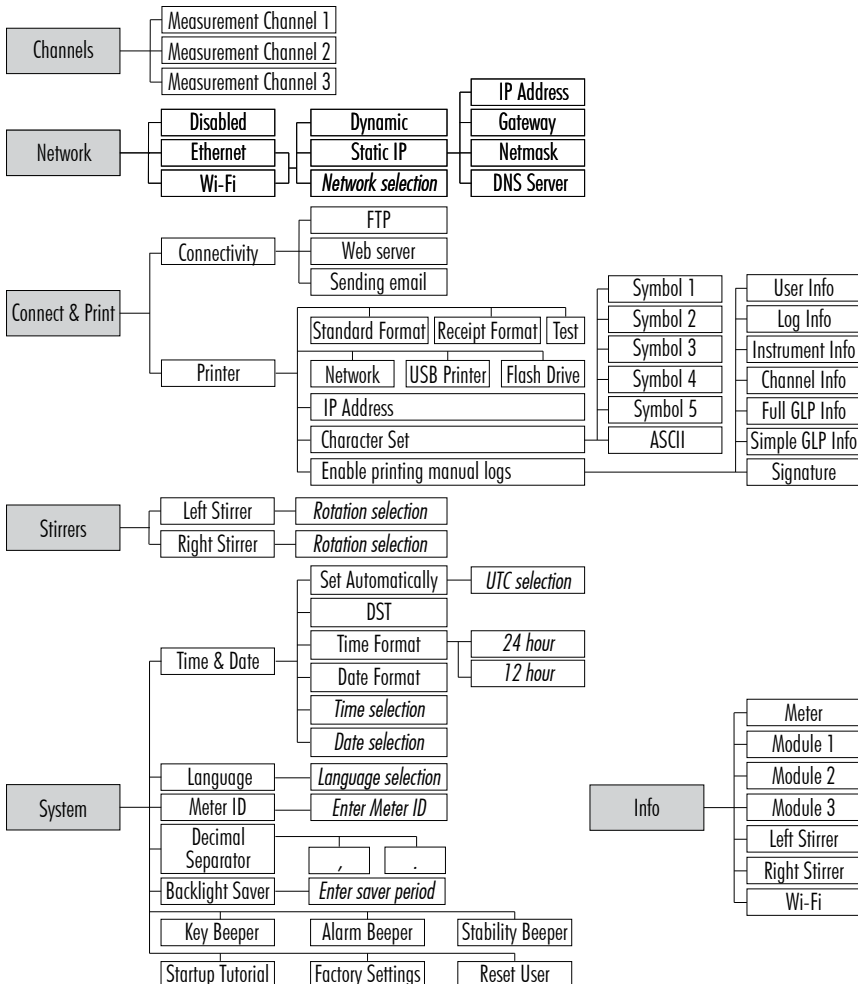
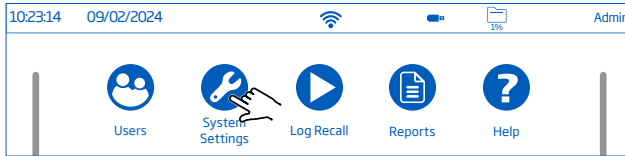

Channels

Up to three hardware modules can be installed in the HI6000. The installed hardware module is assigned to a measurement channel.

Up to three measurement channels can be viewed at one time.

Note: A hardware module can be assigned to multiple measurement channels.

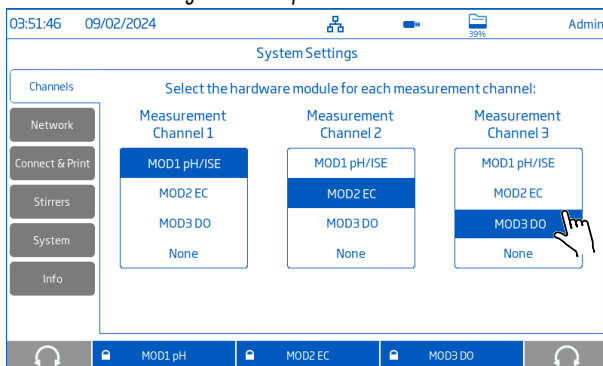

Network

Data sharing options: **Ethernet, Wi-Fi, Disabled**

With connection established, IP assignment can be set as:

- Dynamic, with IP Address, Gateway, Netmask, DNS Server being auto assigned
- Static, with network details being filled in manually

To fill in network information:

- Tap **IP Address** field then input address and tap

Wi-Fi connectivity

1. Tap **Wi-Fi** then select the IP address type (Dynamic or Static).
2. Tap **Press to select network**.
3. Scan options and select preferred network. Enter password if prompted.
4. Tap to confirm.

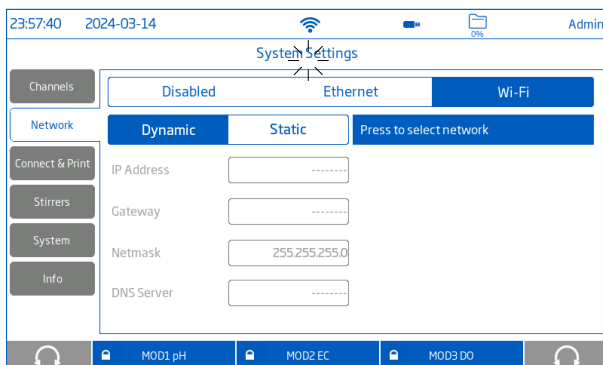

Note: With connection established, tap or to check IP address or verify connection status. When attempting to connect, will blink until the connection is established.

Connect & Print

Options: **Connectivity, Printer, Character Set**

Tap  to enable (disable) following **connectivity** options:

- FTP access to meter: log file transfer to a FTP site and meter FTP server connection to client (log download)
- Meter web server: log file download to a web client
- Sending emails: log file transfer via email

A valid e-mail address is required for file sharing (see 8.1. Users > [Configure user settings](#)).

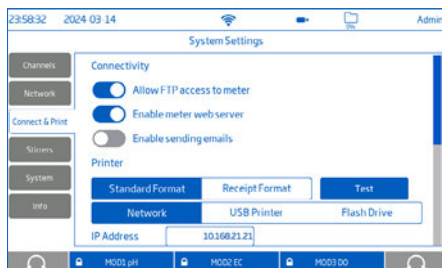

Printer

Options: **Standard Format, Receipt Format, Test**

- Select **Standard Format** to print the delimited text file.
- Select **Receipt Format** to print data as individual points.
- Select **Test** to verify connected printer is correctly configured and produces output correctly.

Refer to printer manual for printer configuration options.

Note: Receipt format can be used on standard sized paper.

Options: **Network, USB Printer, Flash Drive**

- Select **Network** to connect a printer in the same network.
Tap to enter IP address.
- Select **USB Printer** to connect a printer via USB-A port.
- Select **Flash Drive** to export log files directly to USB Flash Drive.

Character Set

Options: **Symbol 1** (character set CP-437), **Symbol 2** (character set CP-1252), **Symbol 3** (character set Roman-8), **Symbol 4** (character set CP-1257), **Symbol 5** (character set CP-1250), **ASCII**

- Select **Symbol 1** to print all ASCII characters as well as some accented letters and Greek letters
- Select **Symbol 2** to print in any Western European language
- Select **Symbol 3** to print in Latin-based European languages
- Select **Symbol 4** to print in Baltic languages
- Select **Symbol 5** to print in Central and Eastern European languages
- Select **ASCII** (American Standard Code for Information Interchange) to print in English language

Note: Selected character set must be supported by the printer.



- Tap **Enable printing manual logs**. When enabled, individual data points and enabled fields will be printed every time **M** is pressed.
 - Tap to enable for printing: User, Log, Instrument, Channel, Full GLP, Simple GLP information, Signature.
- Note:** The connection to the printer must be made prior to enabling printing manual logs and fields to be printed.

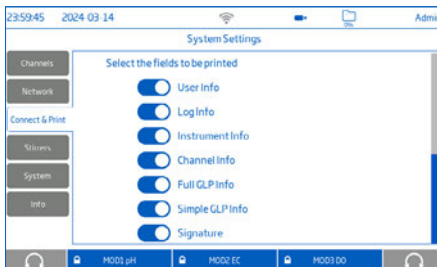

Stirrers

Options: **Clockwise, Counter Clockwise, Alternating 15 sec., Alternating 30 sec., Alternating 45 sec.**

The stirrer rotation can be selected for the left and right stirrer.

With the stirrer plugged in, select the desired rotation: clockwise, counter clockwise, or alternating.

When selecting alternating option, orientation will change between clockwise and counter clockwise after the selected time period has elapsed.

The stirrer speed is set using the slider icon on the system menu screen.

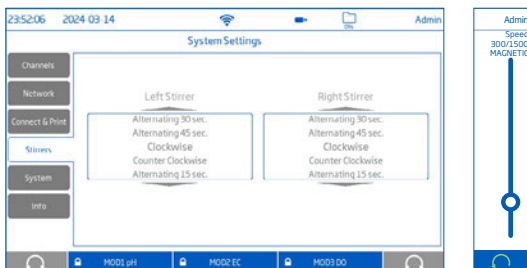

System

Options: **Time, Date, Language, Meter ID, Decimal Separator, Backlight Saver, Key Beeper, Alarm Beeper, Stability Beeper, Startup Tutorial, Factory Settings, Reset User**

Note: Use the scroll bar to view or select from entire settings list.

Time & Date

Tap to enable or disable:

- **Set Automatically** (meter must be connected to the internet)
 - Direct selection from scrollable list of options
 - UTC (Universal Coordinated Time) options:
 - from UTC 00:00 to UTC +14:00
 - from UTC 00:00 to UTC -12:00
- **DST** (Daylight Savings Time) seasonal time change is used in some locations that advance clocks (typically by one hour) during warmer months.

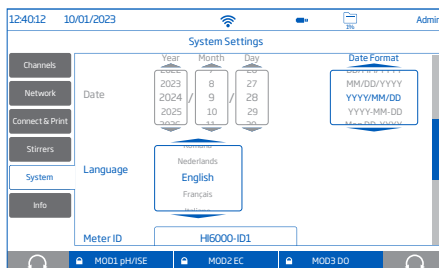
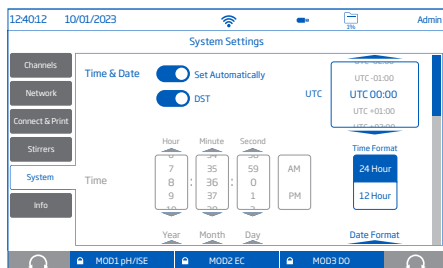
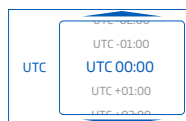

Time: Hour, Minute, Second

Date: Year, Month, Day

Note: Set Automatically use must be disabled to set the time and date manually.

Time Format: 24-Hour, 12-Hour (AM/PM)

Date Format: DD-Mon-YYYY; YYYY-Mon-DD; DD/MM/YYYY; MM/DD/YYYY; YYY/MM/DD; YYYY-MM-DD; Mon DD, YYYY

Language: select from list of supported options to change meter's interface language

Meter ID (Admin only)

- Name the meter with a discrete name, location, or number.
- Tap  to save.

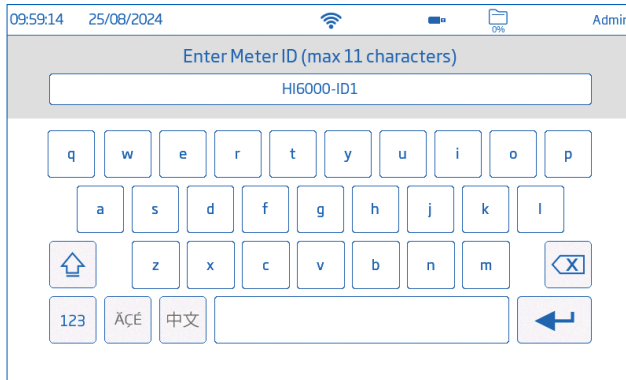

Tap  or corresponding tab to configure following settings:

- **Decimal Separator:** comma or period
- **Backlight Saver:** disabled or enabled, 1 to 60 minutes
If the backlight turns off after the set period of time, tap to turn it back on.
- **Beeper:** Key, Alarm, Stability
When enabled, an audible signal alerts users in the event of a wrong key press, an alarm condition, or the stability threshold being exceeded.
- **Startup Tutorial:** enabled or disabled
If disabled, the meter does not launch the tutorial at start-up.

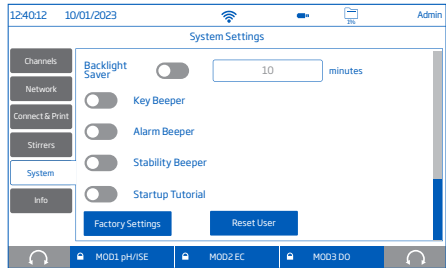
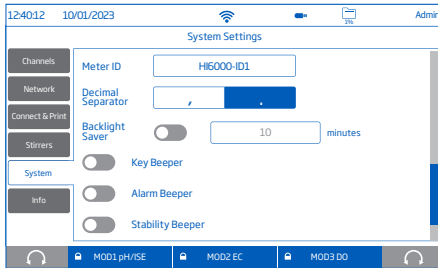

Factory Settings (Admin only)

Option restores system settings e.g. resolution for measured data, temperature unit, view mode, and alarms to original factory values. Restoring factory settings deletes all user information, calibrations, logs, or configured measurement profiles. When option invoked, the instrument asks for confirmation.

Note: The HI7641133 opdo[®] probe stores calibration data on the probe and will not be cleared of data if this function is exercised with the probe connected.

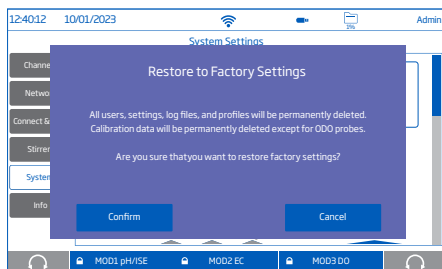

Reset User

Option restores default settings for this user. All data (including profiles and log files) specific to this user will be permanently deleted, except for the username, password, and calibrations.

When option invoked, the instrument asks for confirmation.

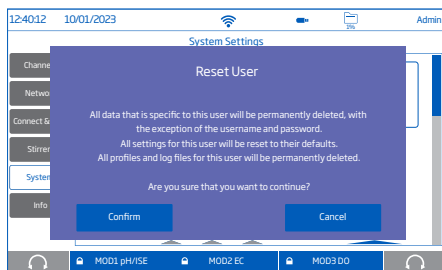

Info

Info displays meter, installed hardware modules, connected stirrers, and Wi-Fi information.

If a HI7641133 opdo probe is connected, the probe and Smart Cap information is displayed.

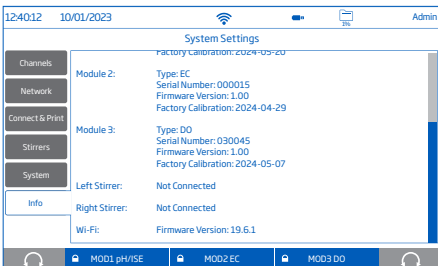
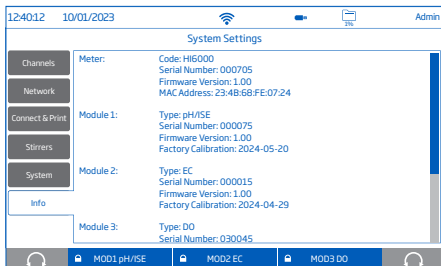

8.3. LOG RECALL & REPORTS

Log Recall and **Reports** are the third and fourth items under the System’s Menu.

Data selection, data viewing, data sharing, deletion of log files, and method-specific application reports are available when accessing LogRecall and Reports.

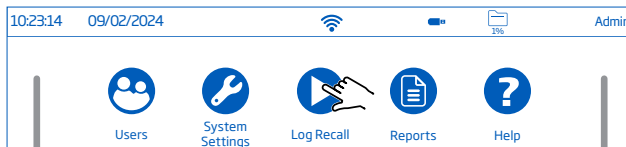

- Logged data is retrieved by the user that has logged the measurement.
- Data is stored in parameter-specific .CSV files.
- Storage location is independent.
 - Automatic and manual log are organized by lots and method data by reports.
- A lot (file) can store 1 to 50 000 data points.
- One user can store up to 255 MB of data points and report files.

View

From the System Menu screen:

1. Tap followed by to display the Log Recall screen. Alternatively, tap to display the method reports.

The log files or reports can be sorted by name or start time.



Tap on the corresponding table header, then tap the to reverse the order.

The screenshot shows the 'Log Recall' screen with a table of log files. The top bar shows the time 04:47:08 and date 2024-03-14. The table has columns for Name, Parameter, Module, Start/Stop, and #Samples. The first row is highlighted in grey.



Name	Parameter	Module	Start/Stop	#Samples
20240129_125909-pH_auto2.csv	pH	MOD2 pH	12:59:09 2024-01-29 13:05:37 2024-01-29	389
20240131_214635-relmV__002_2.csv	Rel. mV	MOD2 pH	21:46:35 2024-01-31 21:46:47 2024-01-31	7
20240228_172444-pH__002_2.csv	pH	MOD2 pH	17:24:44 2024-02-28 17:24:56 2024-02-28	11
20240229_122742-mV__002_1.csv	mV	MOD1 pH/ISE	12:27:42 2024-02-29 12:27:50 2024-02-29	3
20240229_155539-ec_auto2.csv	Conductivity	MOD2 EC	15:55:39 2024-02-29 15:55:54 2024-02-29	16
20240229_161615-do_auto2.csv	DO Sat	MOD2 DO	16:16:15 2024-02-29 16:16:46 2024-02-29 16:16:55 2024-02-29	32

2. Tap to select .CSV file, then **View** to open the file.

Log Recall

- Tap  or  to have logged data displayed in tabulated form or plotted.
- Tap  to view additional information about the log file including user information, log information, meter information, channel information, and GLP data.

04:49:43 2024-03-14 Admin

20240129_125909-pH_auto2.csv   

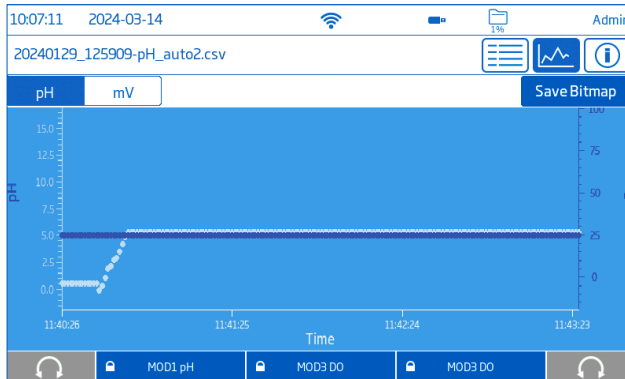

Index	Date	Time	pH	mV	T[°C] ATC2	Notes
1	2024-01-29	12:59:09	2.87	244.1	25.0	OK
2	2024-01-29	12:59:10	0.75	369.5	25.0	OK
3	2024-01-29	12:59:11	2.53	264.5	25.0	OK
4	2024-01-29	12:59:12	1.33	335.4	25.0	OK
5	2024-01-29	12:59:13	3.01	235.9	25.0	OK
6	2024-01-29	12:59:14	1.93	299.7	25.0	OK
7	2024-01-29	12:59:15	1.93	299.7	25.0	OK
8	2024-01-29	12:59:16	2.56	262.9	25.0	OK
9	2024-01-29	12:59:17	1.53	323.8	25.0	OK
10	2024-01-29	12:59:18	3.50	207.0	25.0	OK

MOD1 pH MOD2 EC MOD3 DO



With USB flash drive connected, tap **Save Bitmap** to save plotted data as image.

04:50:39 2024-03-14 Admin

20240129_125909-pH_auto2.csv   

USER INFO
 User Name: Admin
 Full Name: John Smith
 Info 1: Hanna Instruments
 Info 2: Addr
 Info 3:
 Info 4:

LOG INFO
 Log Note:
 Log Info 1:
 Log Info 2:

MOD1 pH MOD2 EC MOD3 DO

Reports

Tap  to view the report data. Displayed information will vary based on the method.

Tap  to view additional information about the log file including the user information, log information, meter information, channel information, and GLP data.

Delete

Deleting logs frees up log space for additional log files and method reports.

1. Select the log files and method reports to be deleted.
Multiple files can be selected individually or all files can be selected using **Select All**.
2. Tap **Delete**.

The instrument prompts for confirmation. Deleted files can not be recovered.

If all of the files have been deleted the log recall screen will be blank.

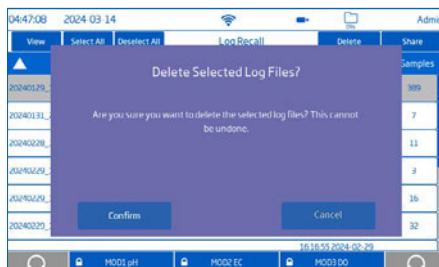

Share

Options: **USB, FTP, Email, Print, Web Server**

USB

1. Plug the USB-A or USB-C flash drive into the USB port located on the back.
2. Select the log files to be shared.
Multiple files can be selected individually or all files can be selected using **Select All**.
3. Tap **Share**.
4. Tap to select USB-A or USB-C.
 is displayed during data transfer.
Transfer completion is confirmed and the instrument returns to Log Recall screen.

FTP

HI6000 can act as an FTP server (host) or client.

Meter has to be connected to the internet and **Allow FTP access to meter** enabled.

See [8.2. System Settings > Connect & Print](#) section.

- Use meter's IP address and password to connect and view logged files.
- Enter in the FTP dedicated fields own server information, in order to export logged files to the FTP server.
- Configure FTP server information in the User menu () to use the meter as an FTP client and upload files to an FTP server.

Connect via **FTP** to **meter server**:

1. On preferred FTP software, type the meter's IP address in the host field.
2. Enter the username and password of the user currently logged in.
3. Connect to view the files logged on the meter.



Connect the **meter** to an **FTP server** and share logs:

1. Select the log files to be shared.
Multiple files can be selected individually or all files can be selected using **Select All**.
2. Tap **Share**.
3. Tap to select FTP.
The files are being transferred in the root folder of the server. ⏱ is displayed during data transfer.
Transfer completion is confirmed and the instrument returns to Log Recall screen.

FTP server installation and configuration

- PC running Windows10 or later
- Password protected Windows account
- FTP server must be allowed through the Windows Firewall

Installation

1. Navigate to **Start > Control Panel > Administrative tools > Server Manager**.
2. Go to **Roles** and expand **Web Server**.
3. Right click on **Web Server** and then click on **Add Role Services**.
4. Go to **Role Services** and check **FTP Server**.
5. Ensure **IIS Manager** (Internet Information Services) is checked under **Management Tools**.
6. Click **Next** followed by **Install**.
7. Wait for installation to complete.

Configuration (PC must be running Windows10 or later)

1. Navigate to **Start > Control Panel > Administrative tools > IIS Manager** (Internet Information Services).
2. Double click to expand the **IIS Manager** console.
3. Right click on **Sites**, on the Connection pane.
4. Click on **Add FTP Site**, to select. Type the FTP server name and the path to be used for file transfer

Note: Select *Make New Folder to create a designated folder to store FTP files*.

5. Click **Next**.
6. In the Binding and SSL Settings window, keep all default settings but change the SSL option to **No SSL**.
7. Click **Next**.
8. When prompted to authenticate and authorize information, select **Basic and Specified** users.
9. Type local account name to gain access to the server.
10. Check both **Read** and **Write** options.
11. Click **Finish**.

Email

Meter has to be connected to the internet and sending emails is enabled.

See [8.2. System Settings](#) > [Connect & Print](#) section.

Enter email address in the User menu (👤) to share log files via email.

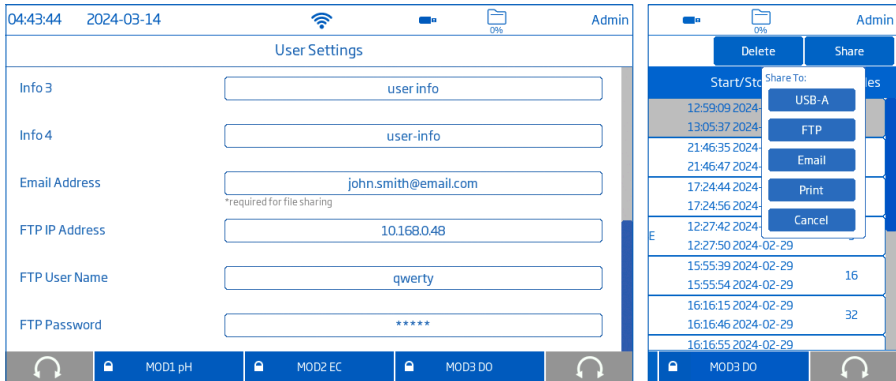

1. Select the log files to be shared.
Multiple files can be selected individually or all files can be selected using **Select All**.
2. Tap **Share**.
3. Select **Email**.
4. Tap to select email.
The files are being emailed. ⏱ is displayed during data transfer.
Transfer completion is confirmed and the instrument returns to Log Recall screen.

Print

1. Connect either a printer (Network or USB) or plug-in a USB Flash Drive.
See [8.2. System Settings](#) > [Connect & Print](#) section.
2. Select the log files to be printed.
Multiple files can be selected individually or all files can be selected using **Select All**.
3. Tap **Share**.
4. Tap **Print** and follow on-screen instructions.

Web Server

Any browser can be used to access the web server and download log files. Meter has to be connected to the internet and meter web server enabled. See [8.2. System Settings](#) > [Connect & Print](#) section.

Note: Both the meter and the web have to be connected to the same network.

1. Tap  for IP address and type address in the browser.



2. Enter the username and password of current user to gain access to logs. Click on file to download to the PC.

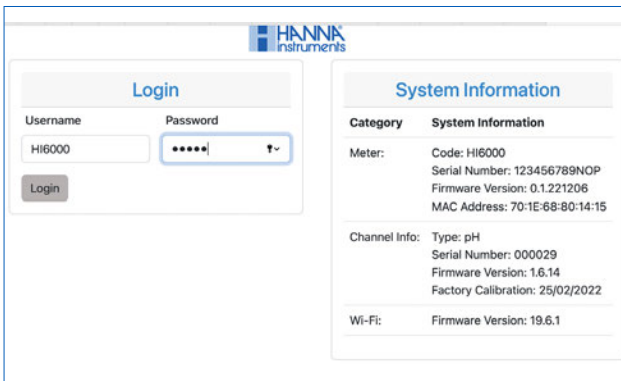

The screenshot shows the "logs" section of the HANNA Instruments web interface. It contains a table with columns for File Name, Parameter, Number of Entries, Start Time, and Stop Time. Each row represents a log file with "Download" and "View" buttons.

File Name	Parameter	Number of Entries	Start Time	Stop Time		
20231117_084933-pH_auto.csv	pH	36	08:49:33 17/11/2023	08:50:08 17/11/2023	Download	View
20231117_085027-pH_auto.csv	pH	42	08:50:27 17/11/2023	08:51:08 17/11/2023	Download	View
20231117_085116-pH_auto.csv	pH	26	08:51:17 17/11/2023	08:51:42 17/11/2023	Download	View
20231117_085705-pH_auto.csv	pH	2	08:57:05 17/11/2023	08:57:06 17/11/2023	Download	View
20231117_090941-pH_new_log_002.csv	pH	13	09:09:41 17/11/2023	09:10:10 17/11/2023	Download	View
20231208_082926-mV_auto.csv	mV	26	08:29:26 08/12/2023	08:29:51 08/12/2023	Download	View
20231208_083012-relmV_auto.csv	Rel. mV	21	08:30:12 08/12/2023	08:30:32 08/12/2023	Download	View

PC Connection

The logged data can be transferred from the meter to a PC.

1. Use the USB-C cable to connect the meter to the PC. The meter appears as a flash drive on the computer.
2. Select the log files to be shared.

Multiple files can be selected individually or all files can be selected using **Select All**.

3. Tap **Share**.

4. Save files to the PC.

All files will be listed as .CSV and may be opened with any text editor or spreadsheet application.

8.4. HELP

Help is the fifth item under the System Menu.

- Tap  to access support and navigate through an overview of system’s main functionalities.

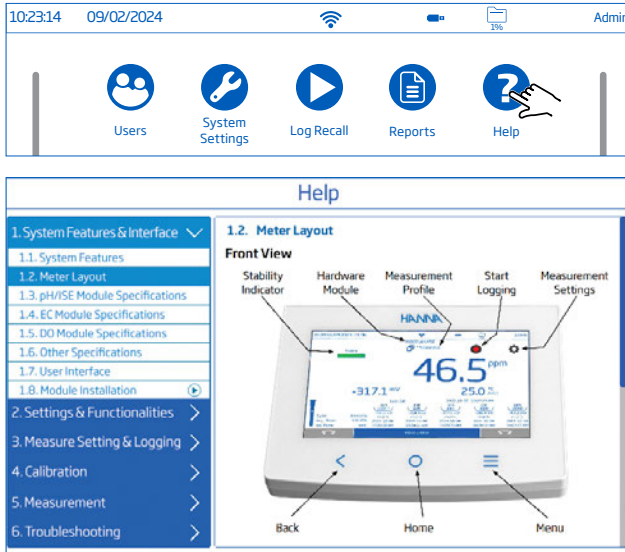

- Tap to play (stop) video-supported segments.

- Tap  once to increase video speed.

The meter supports three playback speeds increasing with each tap:

- normal (×1)
- medium (×2)
- fast (×4)

9. MEASUREMENT SETTINGS

- Tap  icon (**Measurement Settings**) to access Measurement Settings screen. Measurement Settings has the following tabs to help the user navigate through all the measurement operations: **Calibration**, **Reading**, **Temperature**, **View**, **Alarms**, **Logging**, **Profiles**.
- For additional information on calibration, reading, temperature, and additional information about the view, see the related measurement sections.

9.1. VIEW

Users can select what information is displayed on the measurement screen. Select **View** tab to select a preferred display configuration.

Basic

Screen displays the measured value, measurement unit, stability, and temperature compensation status and source.



Simple GLP

Screen displays the last calibration date and time, and basic calibration information. The displayed information will vary based on the hardware module and parameter selected.

Note: If the calibration is not available, “Not Calibrated” is displayed. Simple GLP is not available for all reading modes.

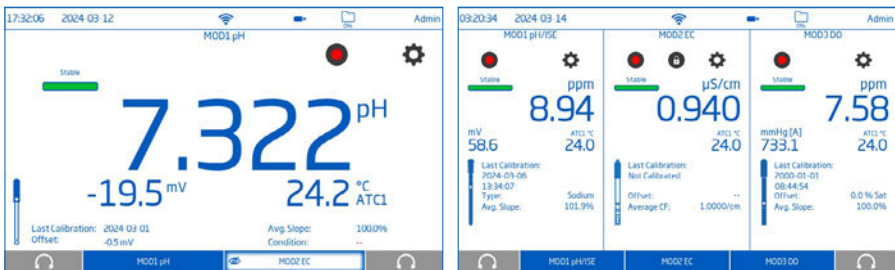

Full GLP

Screen displays the last calibration date and time, and full calibration information.

The displayed information will vary based on the hardware module and parameter selected.

Full GLP is not available when three measurement channels are visible on the measurement screen.

Note: If the calibration is not available, “Not Calibrated” is displayed. Simple GLP is not available for all modes.



Graph

Measured values are plotted as a graph that can be zoomed and panned.

Graph is not available when three measurement channels are visible on the measurement screen.

To zoom in on the graph, select the time or parameter axis and pinch on the display. Once zoomed the graph position can be adjusted by dragging on the display.

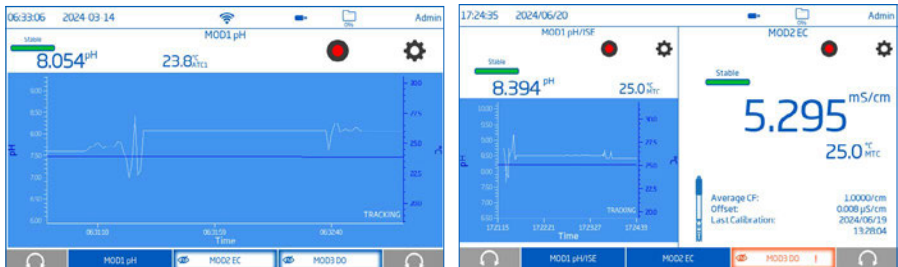

Table

When Table is selected, the measured values are displayed tabulated with date, time, notes made during logging. The newest data is displayed on the top of the table.

Table is not available when three measurement channels are visible on the measurement screen.

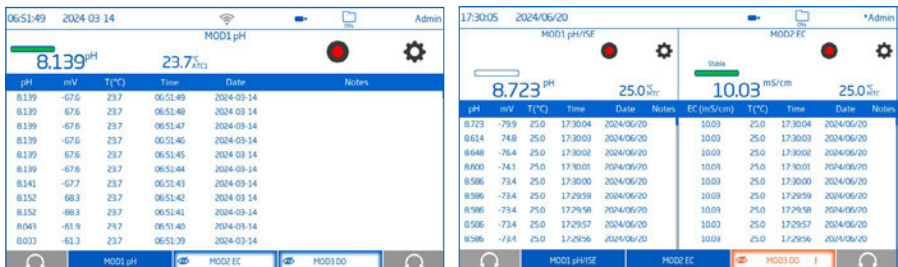

9.2. ALARMS

Options: **High / Low** threshold limits (module specific)

Users can set the threshold limits for the measured parameters.

When enabled, the measurement exceeds the high-threshold value or drops below the low-threshold value, the alarm is triggered, and an alarm message is displayed. If the alarm beeper is enabled, an audible beep will be heard.

Select the **Alarms** tab to configure module-specific alarm options.

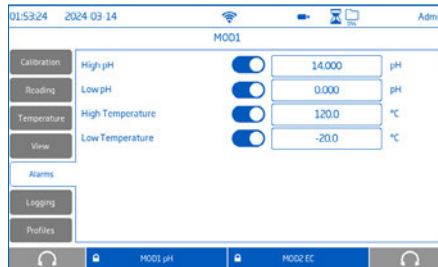

To set an alarm limit:

1. Tap  to enable high or low alarm.
2. Use the on-screen keypad to enter the value.

Alarm values cannot exceed the corresponding high or low alarm.

3. Tap **Save** to confirm.

Alternatively, tap **Cancel** to exit and return to measurement settings.

9.3. LOGGING

A complete set of GLP information including date, time, mode selection, temperature reading, and calibration information is stored with each log. User and log information (e.g. company address or sample details) are included on the .CSV file.

Company information may be entered on the Logging tab in the measurement settings.

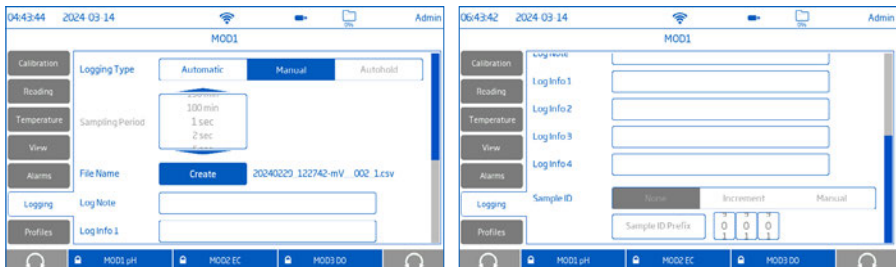

User information is entered in the User menu in the system menu.



Logging Type & Log Naming Convention

Options: **Automatic, Manual, Autohold**

Automatic

- Readings are logged at predefined time intervals, from 1 second to 180 minutes. Tap  to start.
- Records are continuously added to the log until the session stops. Tap  to stop.
- For each automatic logging session, a new log file is created.
A file name is automatically generated, with the year, month, date and log starting time, e.g. 20240329_085101-do_auto.CSV. Files are identified by parameter e.g. pH, mV, DO, EC.

Manual

- Readings are logged every time  is tapped.
- All manual readings are stored in a single log (e.g. records made on different days share the same log).
- A file name is automatically generated with the year, month, date and log starting time, e.g. 20240329_085101-do_001. Files are identified by parameter.
- Tap **Create** to name a manual log file with a custom suffix, e.g. 20240404_13570-do_River samples.

Autohold

- Available with Direct/Autohold reading mode only.
- Readings are logged each time  is tapped and configured stability criteria is reached.
- A file name is automatically generated, with the year, month, date and log starting time, e.g. 20240329_085101-do_001.
- Tap **Create** to name a manual log file with a custom suffix, e.g. 20240404_13570-do_River samples

Notes:

- *Manual and Autohold records are stored in the same log file, e.g. data logged on different days is stored in the same file. Automatic records are stored separately.*
- *Data logged with Autohold option selected is identified by “H” in the Notes column.*
- *Data logged with Manual option selected may have a custom name added. See _water sample_ records in example below.*
- *Data logged with Automatic option selected have _auto in the name.*

View		Select All	Deselect All	Log Recall	Delete	Share
Name	Parameter	Module	Start/Stop	#Samples		
			03:27:56 2024/06/10			
20240610_032818-do_auto1.csv	DO mg/L	MOD1 DO	03:28:18 2024/06/10 03:29:33 2024/06/10	76		
20240610_032827-pH_auto3.csv	pH	MOD3 pH/ISE	03:28:27 2024/06/10 03:29:20 2024/06/10	54		
20240610_043140-pH_auto3.csv	pH	MOD3 pH/ISE	04:31:40 2024/06/10 04:32:41 2024/06/10	62		
20240610_045829-pH_auto3.csv	pH	MOD3 pH/ISE	04:58:29 2024/06/10 04:58:39 2024/06/10	11		
20240610_235013-pH_water samples_002_3.csv	pH	MOD3 pH/ISE	23:50:13 2024/06/10 23:50:38 2024/06/10	8		
20240610_235218-do_002_1.csv	DO Sat	MOD1 DO	23:52:18 2024/06/10 23:52:24 2024/06/10	7		

Sampling Period

Options: 1, 2, 5, 10, 30 sec., 1, 2, 5, 10, 15, 30, 60, 120, 150, 180 min.

Option available with **Automatic** logging type only.

Time-interval option is from scrollable list.

File Name

Option available with **Manual** and **Autohold** logging type only.

To create a file name, from Logging screen:

1. Tap **Create**.
2. Use the keypad and enter file name (maximum 13 characters).
3. Tap  to confirm.

Log Note & Log Info

Notes on measured data are saved together with logged data.

Sample ID

Manual and autohold samples can be labeled with a text label and numerical ID.

With **Increment** selected:

1. Tap **Sample ID Prefix**.
2. Use the on-screen keypad to enter a text prefix to the sample name (maximum 15 characters).
3. Tap  to confirm.
4. Select ID number from scrollable list.

The ID number will increment with each new sample logged.

With **Manual** selected:

1. Tap **Sample ID Prefix**.
2. Use the on-screen keypad to enter a text prefix to the sample name (maximum 15 characters).
3. Tap  to confirm.

When the measurement is logged, a pop up is displayed and the sample ID can be modified.

9.4. PROFILES

A profile is a sensor setup complete with required measurement unit, temperature unit, display preference, and alarm threshold options. Once saved the profile can be loaded for applications that require similar configurations.

Saved profiles are only accessible by the user who created it.

Select **Profiles** tab to configure measurement profiles.

Profile Feature

Tap  to enable or tap  to disable the option.

With option enabled, profile operations are active.

The default profile is always available with the factory settings.

After any modification to Calibration, Reading, Temperature, View, or Alarms tabs, the name of the current profile is indicated with **(Modified)***.

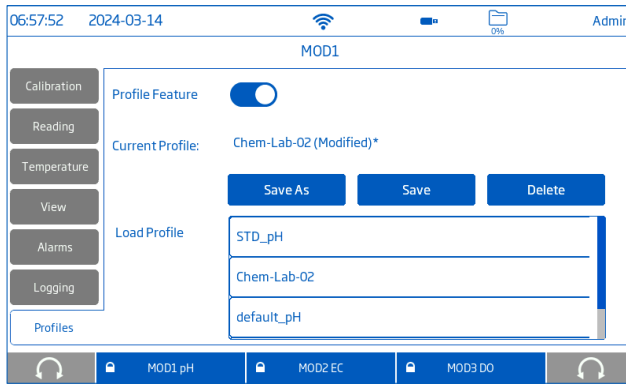

The  icon (Profile icon) is displayed on the measurement screen.

When one measurement channel is visible, the profile name is displayed next to the icon.

When two or three measurement channels are visible, the profile name can be displayed only when tapping the profile icon.

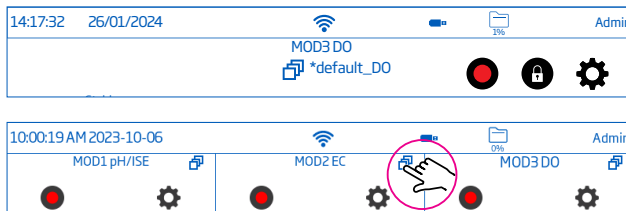

To save a profile, having previously configured all other application-specific options from the measurement settings:



1. Tap **Profiles** tab.
2. Tap **Save As** and use the keypad to enter profile name (maximum 20 characters).
3. Tap  to confirm.
4. Once saved, profile name is added to the Load Profile list.

Load Profile



- Tap to select a configured profile from the Load Profile list.
- Profile name is automatically entered in the Current Profile field.

10. LOGGING

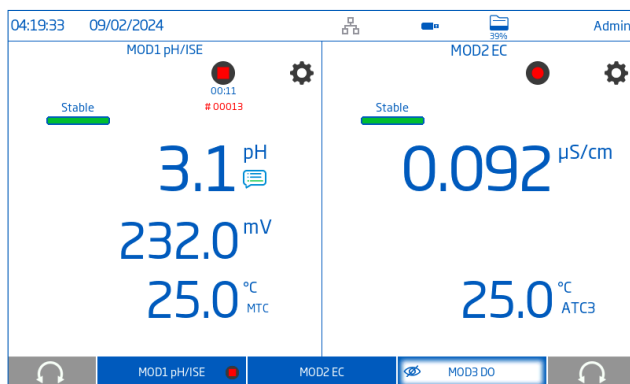

10.1. AUTOMATIC LOGGING

1. From Measurement screen, tap .
2. Tap **Logging** tab and then select **Automatic** logging type.
3. Scroll to select Sampling Period.
4. Log Note and Log Information can be entered.
See section [9.3. Logging](#) for more details.
5. Tap  to return to the measurement screen.
6. Tap  to start logging.













7. During active logging, users can add a note to the logged sample. Notes are visible in log recall and .CSV files.
 - Tap  to add note to the sample.
 - Use on-screen keypad to enter text.
 - Tap  to save entered note.
8. Tap  to stop the log.



Automatic logging with Autohold

1. Tap **Reading** tab and then select **Direct/Autohold** reading mode.
2. Tap **Logging** tab and then select **Automatic** logging type.
3. Tap  to return to the measurement screen.
 - The log will be started as soon as  is tapped.
All data will be added to the log at the selected sampling period.
 - Tap the  to initiate an autohold reading.

Once the stability criteria has been met, the value will be held on the screen and the  is displayed.

At the selected sampling period this value will be saved to the log. In the log file a "H" is displayed in the notes column. The reading being held on the screen, will continue to be saved at the selected sampling interval.



4. Users can add a note to the logged sample. Notes are visible in log recall and .CSV files.
 - Tap  to add a note to the sample.
 - Use on-screen keypad to enter text.
 - Tap  to save entered note.
5. Tap a parameter icon — , , , , , , ,  — to release the autohold reading and continue logging at the selected sampling period.

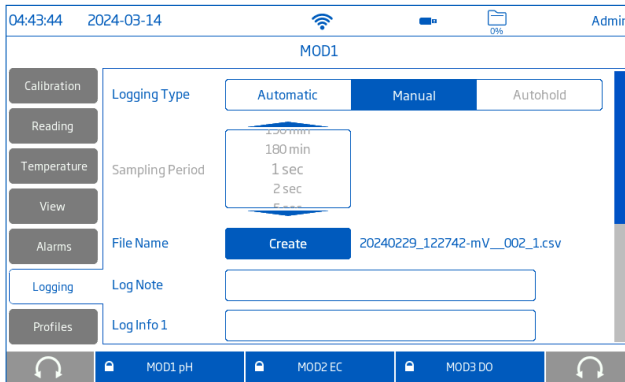

Additional autohold reading can be initiated by tapping the  icon.
6. Tap  to stop the log.

10.2. MANUAL LOGGING



1. From Measurement screen, tap .
2. Tap **Logging** tab and then select **Manual** logging type.
3. Tap **Create** to enter a file name.



4. Tap **Increment** to set a sample name (prefix and sample ID).
5. Tap  to return to the measurement screen.
6. Tap  to log data. Data is logged every time symbol is tapped.

If Manual sample ID was selected, use the on-screen keypad to enter the sample ID and notes on the pop-up.
7. Users can add a note to the logged sample. Notes are visible in log recall and .CSV files.
 - Tap  to add a note to the sample.
 - Use on-screen keypad to enter text.
 - Tap  to save entered note.

Manual logging with Autohold

1. From Measurement screen, tap .
2. Tap **Reading** tab and then select **Direct/Autohold** reading mode.
3. Tap **Logging** tab and then select **Manual** logging type.
4. Tap **Create** to enter a file name.
5. Tap **Increment** to set a sample name (prefix and sample ID).
6. Tap  to return to the measurement screen.

7. Tap **M** to save a reading to the log file.
8. Tap **A** to initiate autohold.
Once the stability criteria has been met, the value will be held on the screen and the **Autohold** is displayed.
9. Tap **M** to save the autohold reading to the log file.
In the log file a "H" is displayed in the notes column.
10. Tap a measure parameter icon — **pH**, **mV**, **ISE**, **EC**, **Res**, **TDS**, **Sal**, **DO** — to release the autohold reading.
Additional autohold reading can be initiated by tapping the **A** icon.

10.3. AUTOHOLD LOGGING

1. From Measurement screen, tap **⚙**.
2. Tap **Reading** tab to select stability criteria.
Option to select between Accurate, Medium, or Fast.
- Note: Autohold logging uses this criteria for logging. Setting this will affect when data is recorded.*
3. Tap to select **Direct/Autohold** reading mode.
4. Tap **Logging** tab and select **Autohold** logging type.

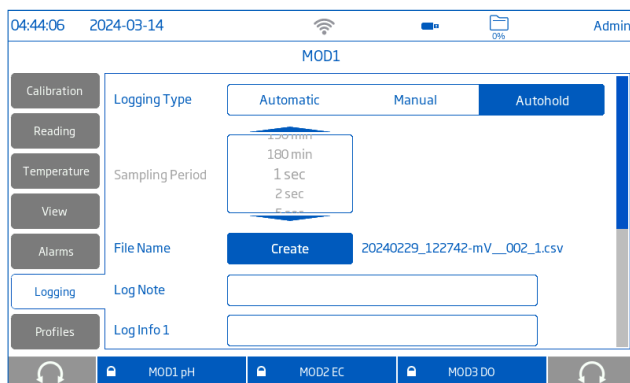

5. Tap **Create** to enter a file name.
6. Tap **Increment** to set a sample name (prefix and sample ID).
7. Tap **⊙** to return to the measurement screen.
8. Tap **A** and **D**. Once the stability criteria is met, the value will be held on the screen and the **Autohold** is displayed and the meter stores the data point in the log file.
9. Tap a measure parameter icon — **pH**, **mV**, **ISE**, **EC**, **Res**, **TDS**, **Sal**, **DO** — to release the autohold reading.
Additional autohold reading can be initiated by tapping the **A** icon.
10. Tap **A** to manually save data point to the log file.
11. Tap **A** to initiate a new Autohold data point.

Note: Autohold logging and Autohold are enabled together, the user will only see one log point added to the data file.

11. pH MEASUREMENTS

11.1. MEASUREMENT SETTINGS

Connect pH electrode to BNC connector on rear of meter.

Tap  from the measurement screen then select the **Reading** tab.

Set the parameter to **pH**.

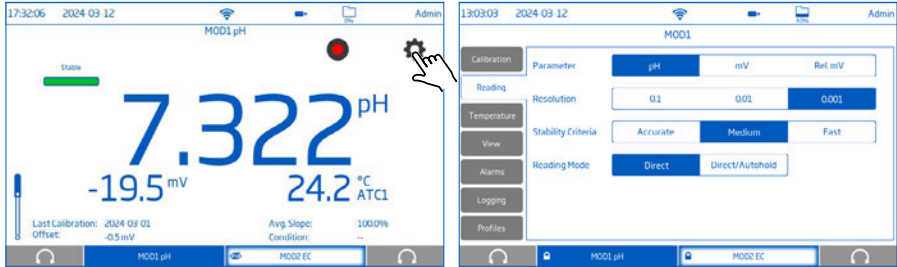

11.1.1. Calibration

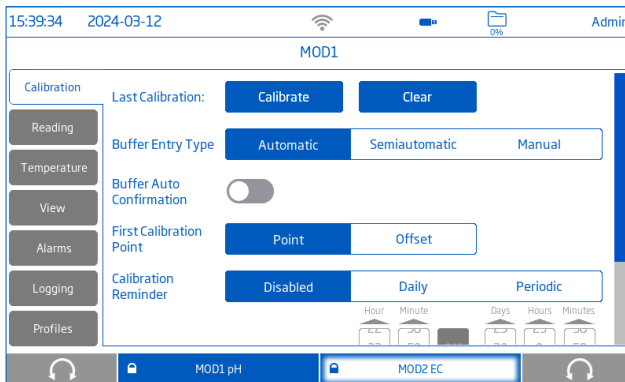

Last Calibration

Options: **Calibrate**, **Clear**

- **Calibrate**: starts a new user calibration.
- **Clear**: deletes the pH electrode calibration for the selected hardware module. A default calibration will replace the actual electrode calibration until a new calibration is made.

Buffer Entry Type

Options: **Automatic**, **Semiautomatic**, **Manual**

- **Automatic**: the instrument automatically selects the closest buffer to the pH value being measured from all active buffers in the buffer group.
- **Semiautomatic**: the instrument automatically selects the closest buffer to the pH value being measured from all available standard and custom buffers.
The user has the option to also manually select the calibration buffer.
- **Manual**: the user manually selects the buffer value from all available standard and custom buffers.

Buffer Auto Confirmation

Options: **Enabled, Disabled**

When enabled, the recognized buffer is automatically accepted when the reading is stable.

First Calibration Point

Options: **Point, Offset**

- **Point:** a new buffer value can be added to an existing calibration. This prompts an automatic reevaluation of the electrode slope.
- **Offset:** the new buffer calibration point creates a constant offset to all existing pH calibration data performed with a minimum of two pH buffers.

Calibration Reminder

Options: **Disabled, Daily, Periodic**

- **Daily:** set the time of day the calibration reminder needs to be displayed.
 - **Periodic:** schedule time in days, hours and/or minutes after the last calibration for the calibration reminder to be displayed.
- “Calibrate probe” is displayed on the screen after the calibration reminder period has elapsed.

Buffer Group

The buffer group is used during calibration when automatic buffer entry type is selected. The instrument automatically selects closest buffer to the pH value being measured from the buffer group.

See [11.2. pH Calibration](#) section for details.

11.1.2. Reading

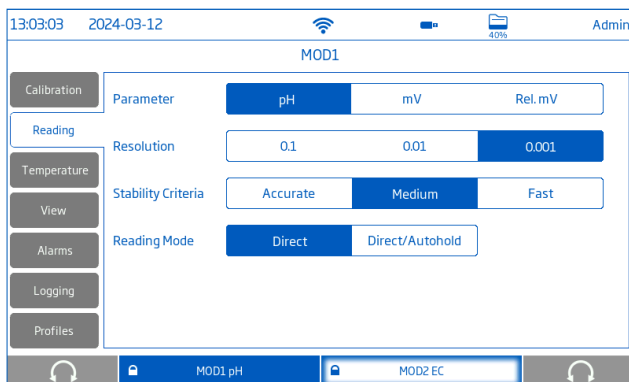

Parameter

HI6000-2 module options: **pH, mV, Rel. mV, ISE**

Tap to select desired measurement configuration.

Resolution

Options: 0.1, 0.01, 0.001

Tap to select the pH measurement resolution.

Stability Criteria



Options: Accurate, Medium, Fast

- **Accurate:** for applications where high accuracy is required.
A measurement is recognized as stable using more critical criteria evaluating measurement fluctuations.
- **Medium:** for applications where average accuracy is accepted.
A measurement is recognized as stable using less critical criteria evaluating measurement fluctuations.
The measurement may still change after registering stable.
- **Fast:** for applications where speed of delivery has priority.

While the measurement is changing, the stability indicator is shown partially (Unstable).
When the criteria is reached, the indicator is displayed as a full green bar (Stable).

Reading Mode

Options: Direct, Direct/Autohold

- **Direct:** as measurement changes measurement stability is continuously evaluated.
"Unstable" (blinking) or "Stable" is displayed above the stability indicator.
- **Direct/Autohold:** measurements are initiated using the  icon.
When the measurement is stable, it is frozen on the display.
The  icon is used to release the autohold reading.

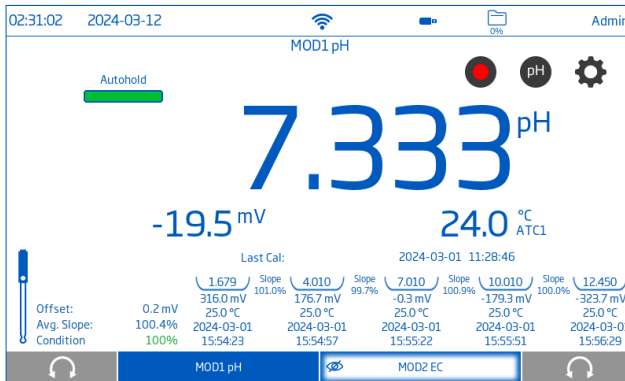

11.1.3. Temperature

Temperature Source

Options: **Automatic (MOD1, MOD2, MOD3), Manual**

User can select between physical temperature input source (MOD1, MOD2, MOD3) or entering sample temperature value manually.

- **Automatic** with temperature probe
 - ATC is displayed next to the temperature measurement on the measurement screen.
- **Manual** without temperature probe
 - MTC is displayed next to the temperature measurement on the measurement screen. Sample's temperature needs to be entered.

Temperature Unit

Options: °C, °F, K

Tap to select the temperature unit.

Manual

Options: **-20.0 to 120 °C (-4.0 to 248.0 °F, 253.2 to 393.2 K)**

To manually input temperature value:

1. Select temperature unit.
2. Tap the Manual input field.
3. Enter temperature value.
4. Tap  to confirm.

Isopotential Point

Options: **-2.000 to 20.000 pH**

Isopotential point is the point at which temperature has no effect on pH readings.

Unless noted with electrode, use 7.000 pH.

To change the isopotential point:

1. Tap the isopotential point input field.
2. Enter isopotential point.
3. Tap  to confirm.

User Temperature Calibration

Options: **Calibrate**, **Clear**

- **Calibrate**: starts a new user calibration.
- **Clear**: deletes the temperature calibration for the selected hardware module.

To perform a new calibration:

1. Tap **Calibrate**.
2. Place the temperature probe and a reference thermometer with 0.1 resolution into a stirred container of water.
Allow for the reading to stabilize.
3. If the displayed value is different than the reference thermometer reading, touch **Calibrated Temperature** value and use the on-screen keypad to edit.
4. Tap **Save** to confirm and save data.

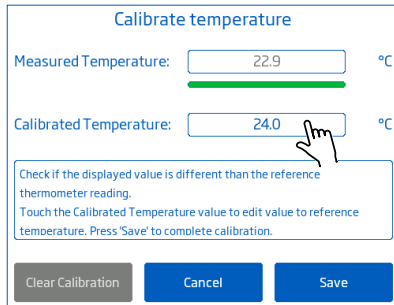

11.1.4. View

Options: **Basic**, **Simple GLP**, **Full GLP**, **Table**

See section 9.1. [View](#) for details.

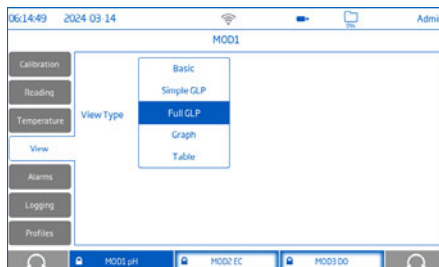

11.1.5. Alarms

Options: **High pH, Low pH, High Temperature, Low Temperature**

See section [9.2. Alarms](#) for details.

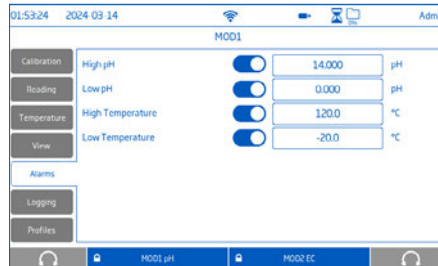

11.1.6. Logging

Options: **Automatic, Manual, Autohold**

See section [9.3. Logging](#) for details.



11.1.7. Profiles

See section [9.4. Profiles](#) for details.

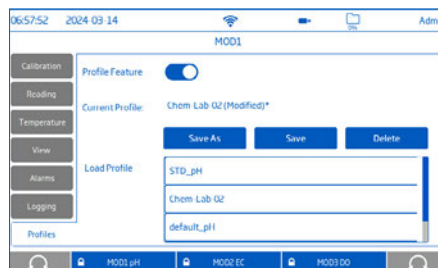

11.2. pH CALIBRATION

11.2.1. Calibration Guidelines

- Set up a routine service schedule where measurement integrity is validated.
- Do not handle the sensing surfaces of the sensors.
- Avoid rough handling and abrasive environments that can scratch the reactive surfaces of the sensors.
- For best technique, use a rinse beaker and a separate calibration beaker for each buffer.
- Do not return the used buffers to the bottles of “fresh” buffer. Discard buffers after use.
- For measurements across a temperature gradient (when sample temperature is drastically different from the buffers), allow the electrodes to reach thermal equilibrium before conducting calibrations or making measurements.
- During calibration the temperature probe should be in the calibration buffer.



11.2.2. Buffer Group (Automatic Calibration Only)

In addition to selecting from eight standard buffers, users can define five custom buffers to be used for calibration. HI6000 automatically recognizes the closest buffer to the pH value being measured from all available (standard and custom) buffers in the buffer group.

To move buffers from **Available Standard Buffers (Available Custom Buffers)** trays to **Buffers in Use** trays:

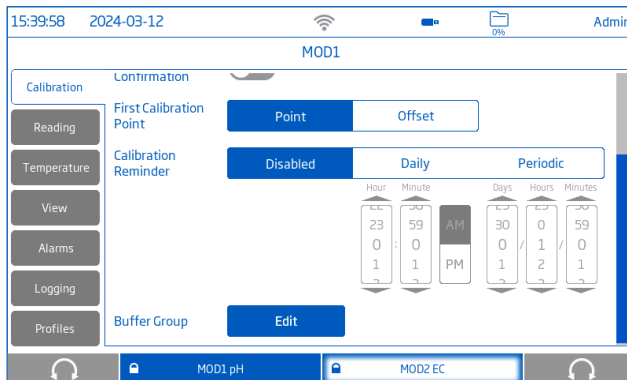
1. Tap .
2. Tap **Calibration** tab.
3. Tap **Edit**.



4. Tap to select from the Available Standard Buffers or Available Custom Buffers trays. A rectangular outline highlights the buffer selected for transfer. For custom values, tap an empty tray to input a new value or an existing tray to edit the buffer value. Follow the Editing Custom Buffers Values steps.
5. Tap  to move the selected buffer in the Buffers in Use column.
 -  displayed next to the buffer value, indicates calibration with a standard buffer.
 -  displayed next to the buffer value, indicates calibration with a custom buffer.

Repeat with up to 5 buffers.

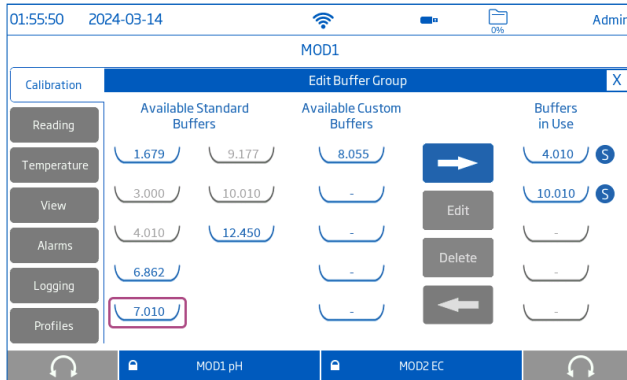

Editing Custom Buffer Values

1. Tap a custom buffer tray from the Available Custom Buffers column.
2. Tap Edit.

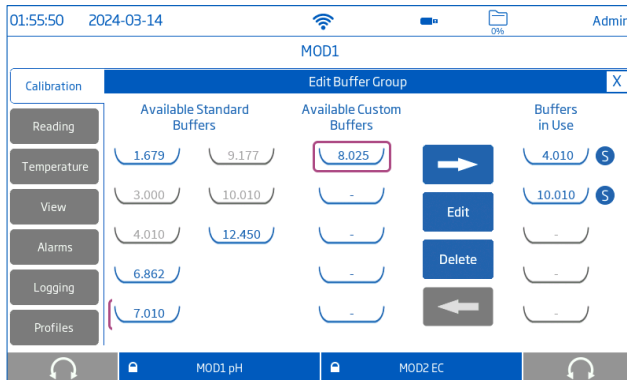

3. Use the numeric keypad to enter a value.
4. Tap  to confirm.

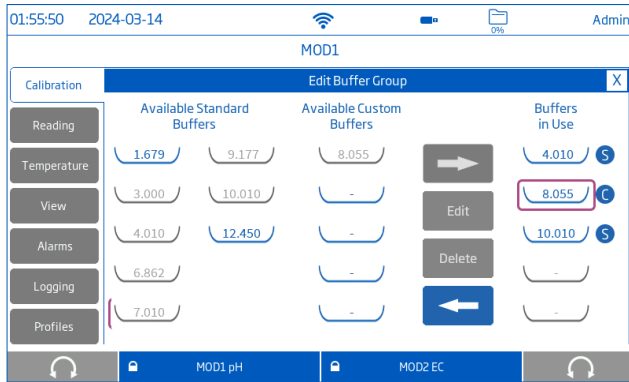

11.2.3. pH Calibration Procedure

With the electrode and temperature sensor connected to the meter:

1. Enter the solution temperature manually if calibration is done without a temperature sensor.
2. Remove the plastic protective cap from the probe and rinse the electrode with purified water.
3. Fill a rinse beaker 2/3 full with the first buffer solution.

For most applications it is recommended to start with pH 7.01 or pH 6.86 buffer.

Use calibration buffers that bracket the samples pH.

For acidic samples it is recommended to use pH 4.01, 3.00, and/or 1.68 buffers.

For alkaline samples it is recommended to use pH 9.18, 10.0, and/or 12.45 buffers.

4. Swirl the electrode and temperature sensor in the buffer solution.
5. Raise and lower the probe several times. Discard the solution.
6. Fill the calibration beaker 2/3 full with the first buffer solution.
7. Slowly place the electrode and temperature sensor in the selected buffer.

Dislodge bubbles that may adhere to the sensors.

8. Tap **Calibrate** and the meter will open a pH calibration screen.

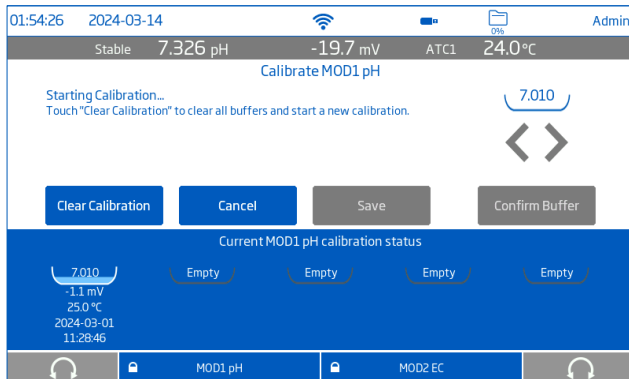

9. If using a new pH electrode it is recommended to tap **Clear Calibration** to clear all buffers and start new.
10. **Automatic Buffer Entry:** the meter will automatically recognize the closest buffer to the pH value being measured from all available (standard and custom) buffers in the buffer group.
Semiautomatic Buffer Entry: the meter will automatically recognize the closest buffer to the pH value being measured from all available (standard and custom) buffers.
 The arrows under the beaker tray can be used to select another buffer value.
Manual Buffer Entry: use the arrows under the beaker tray to select the buffer value from all available (standard and custom) buffers.
11. Wait for the reading to stabilize and tap **Confirm Buffer** to save the calibration point and move to the next buffer.
Note: If probe's response time is slow, clean the probe then repeat the calibration.
 Repeat procedure for a total of five calibration points.

12. Tap **Save** to update the calibration and return to the measurement screen.

11.2.4. Calibration with Millesimal Buffers

Hanna Instruments manufactures millesimal buffers that are certified ± 0.002 pH. The certified values can be used during calibration.

1. Tap .
2. Tap **Reading** tab.
3. Set the resolution to 0.001 and stability criteria to Accurate.
4. Tap **Calibration** tab.
5. Edit the buffer group to include the nominal pH values for the millesimal buffers being used.
6. Following the procedure in [11.2.3. pH Calibration Procedure](#) section prepare the electrode and first calibration buffer.
7. Tap **Calibrate** and the meter will open a pH calibration screen.
8. Wait for the reading to stabilize. A box will be displayed around the recognized buffer.
9. Tap on the box to edit the buffer value. Use the keypad to manually enter the value printed on the certificate and press save.
10. Tap **Confirm Buffer** to save the calibration point and move to the next buffer.
 Repeat procedure for a total of up to five calibration points.
11. Tap **Save** to update the calibration and return to the measurement screen.

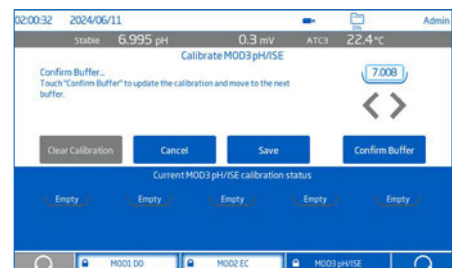
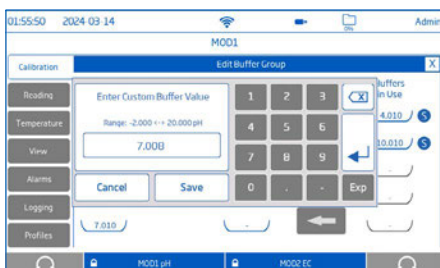



11.2.5. Calibration Messages

Check the buffer value and use fresh buffer if:

- The buffer cannot be recognized.
- The current reading is outside of the acceptable window.
- The current buffer is generating a slope over the of acceptable window.
- Temperature is outside of the acceptable window.
- The current buffer is generating a low slope.
- The current buffer cannot be confirmed due to an inconsistency with the previous calibration. Additionally, clear the old calibration to continue.

Check the buffer value and choose a new buffer if:

- The current buffer has already been accepted or is too close to a buffer that has been used.

11.3. pH MEASUREMENT

11.3.1. Measurement Tips

- Connect the electrode to be used to the appropriate meter input.
Make sure the electrode has been recently calibrated and is working correctly.
 - Place electrode into the [HI764060](#) electrode holder for easy transfer in and out of containers during calibration, sample measurement, and storage.
 - Rinse with purified water between buffers and/or samples.
 - Blot (never rub!) the sensor with a lint-free tissue between buffers and samples.
 - To limit sample contamination, pour two beakers of buffers and samples.
Use one beaker to rinse the sensor and the second for measurement.
- Note:** Use the same size beaker and immersion depth for samples and buffers.
- Gently stir the test sample to ensure the sensor is measuring a representative sample.

- Open the fill hole cover and keep the fill solution topped off to permit the fill solution to flow through the junction and maintain a stable reference signal.
- If measuring across a temperature gradient, allow the sensor to reach thermal equilibrium.
- If using manual temperature compensation, input the sample temperature.
- Once the reading indicates Stable, record measurement data.
- When all samples have been measured, rinse the electrode and replace storage cap with storage solution. Replace fill hole cover.



Note: When working without a temperature sensor, ensure that both calibration and measurements are done at the same temperature. This requires manual input of temperature value to allow the meter to perform buffer temperature compensation.

11.3.2. Direct Readings

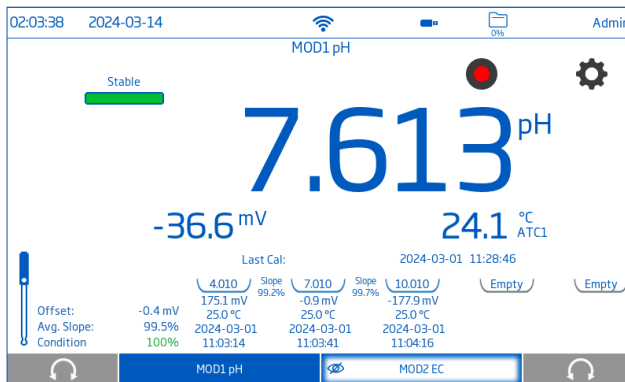
- Place the electrode tip and the temperature probe approximately 4 cm (1.5") into the sample to be measured. Allow time for the electrode to stabilize.
-  is displayed until measurement is stabilized.
- The measured pH value is displayed on the LCD.



11.3.3. Direct / Autohold Readings

- Place the electrode tip and the temperature probe approximately 4 cm (1.5") into the sample to be tested.
- Tap  to enable the autohold reading mode.
- The measured parameter value will be displayed on the LCD.  is displayed blinking.
- Once the stability criteria is reached, the measured value is frozen on the display.  stops blinking.

- To release the autohold and return to direct reading mode, tap **pH**.

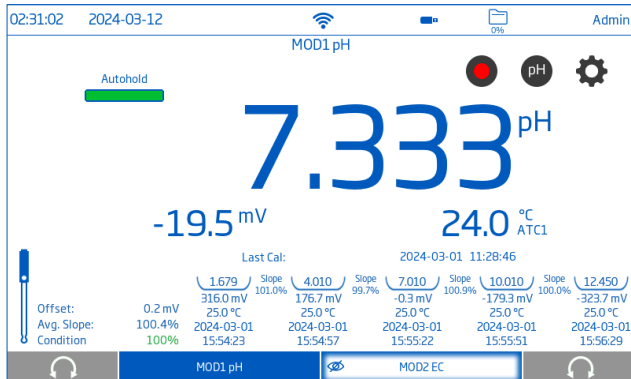

12. ORP MEASUREMENTS

12.1. MEASUREMENT SETTINGS

Connect ORP electrode to BNC connector on rear of meter.

Tap  from the measurement screen then select the **Reading** tab.

Set the parameter to **mV** or **Rel. mV**.

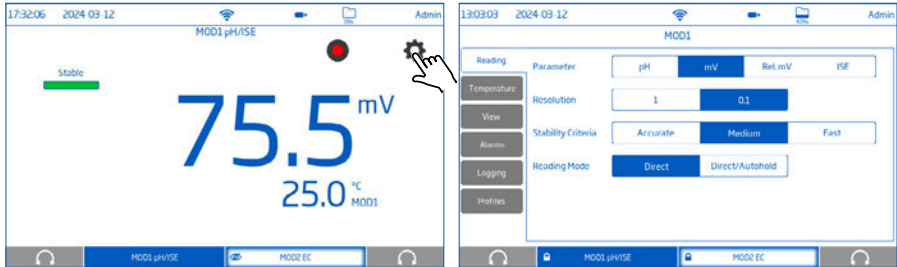

12.1.1. Calibration (Rel. mV Only)



Last Calibration

Options: **Calibrate**, **Clear**

- **Calibrate**: starts a new user calibration.
- **Clear**: deletes the last calibration for the selected hardware module.

A default calibration will replace the actual electrode calibration until a new calibration is made.

Calibration Reminder

Options: **Disabled**, **Daily**, **Periodic**

- **Daily**: set the time of day you wish the calibration reminder to be displayed.
- **Periodic**: schedule time in days, hours and/or minutes after the last calibration for the calibration reminder to be displayed.

“Calibrate probe” message is displayed on the screen after the calibration reminder period has elapsed.

12.1.2. Reading

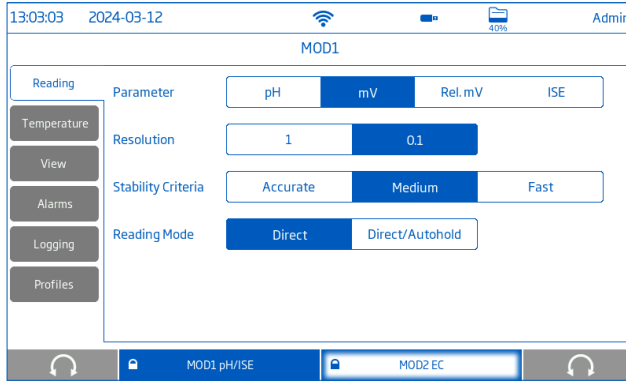

Parameter

Options: pH, mV, Rel. mV, ISE (HI6000-2 only)

Tap to select desired measurement configuration.

Resolution

Options: 1, 0.1

Tap to select the mV measurement resolution.

Stability Criteria

Options: Accurate, Medium, Fast



- **Accurate:** for applications where high accuracy is required. A measurement is recognized as stable using more critical criteria evaluating measurement fluctuations.
- **Medium:** for applications where average accuracy is accepted. A measurement is recognized as stable using less critical criteria evaluating measurement fluctuations. The measurement may still change after registering stable.
- **Fast:** for applications where speed of delivery has priority.

While the measurement is changing, the stability indicator is shown partially (Unstable).

When the criteria is reached, the indicator is displayed as a full green bar (Stable).

Reading Mode

Options: Direct, Direct/Autohold

- **Direct:** as measurement changes measurement stability is continuously evaluated. "Unstable" (blinking) or "Stable" is displayed above the stability indicator.
- **Direct/Autohold:** measurements are initiated using the  icon. When the measurement is stable, the icon is frozen on the display. The  is used to release the autohold reading.

12.1.3. Temperature

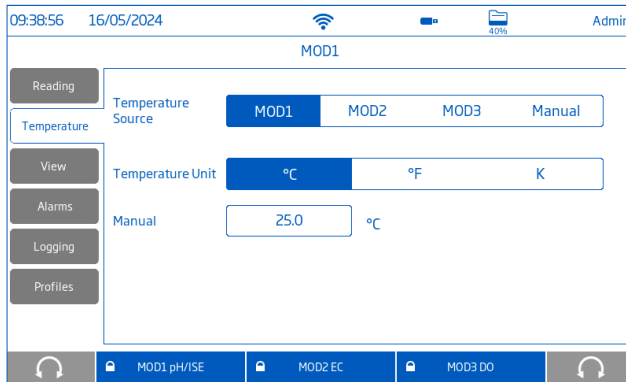

Temperature Source

Options: **MOD1**, **MOD2**, **MOD3**, **Manual**

The user may select a temperature-measurement source installed on MOD1, MOD2, or MOD3, or enter the sample temperature value manually. ORP readings are not temperature compensated, value is recorded for your records only.

Temperature Unit

Options: **°C**, **°F**, **K**

Tap to select the temperature unit.

Manual

Options: **-20.0 to 120 °C (-4.0 to 248.0 °F, 253.2 to 393.2 K)**

To manually input temperature value:

1. Select temperature unit.
2. Tap the Manual input field.
3. Enter temperature value.
4. Tap  to confirm.

12.1.4. View

Options: **Basic**, **Graph**, **Table**, **Simple GLP** (Rel. mV only)

See section [9.1. View](#) for details.



12.1.5. Alarms

Options: **High mV, Low mV, High Temperature, Low Temperature**

See section [9.2. Alarms](#) for details.

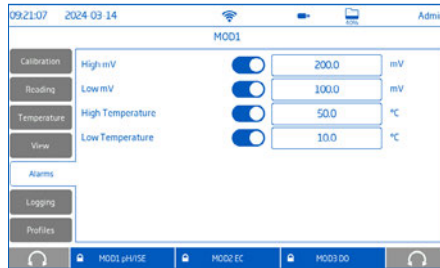

12.1.6. Logging

Options: **Automatic, Manual, Autohold**

See section [9.3. Logging](#) for details.



12.1.7. Profiles

See section [9.4. Profiles](#) for details.

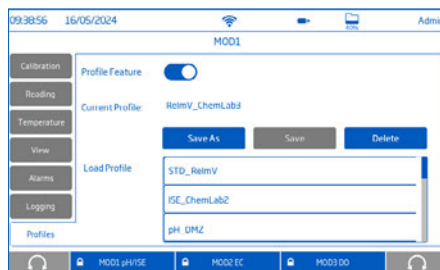

12.2. RELATIVE mV (ORP) CALIBRATION

12.2.1. Calibration Guidelines

- ORP is displayed in mV.
The voltage displayed results from the difference in potential between the platinum (or gold) ORP sensor and the Ag/AgCl reference electrode.
- ORP values are not temperature compensated, although ORP values can change with temperature. ORP values should be reported with the reference electrode used and the temperature.
- The inert noble metal ORP surface provides an electron-exchange site with the sample (or standard) and its surface. The electron exchange is typically very fast in well-poised solutions (e.g. standards) but may be lengthier in actual samples.
- Calibration is used to compensate for changes due to contamination of the platinum surface and drift in the reference electrode. It establishes a baseline that can be used as a comparison for future work.
- A relative mV calibration can also be made to remove the voltage attributable to the Ag/AgCl reference electrode, to display the ORP versus a SHE (Standard Hydrogen Electrode).
For example, [HI7022](#) ORP Test Solution reads 470 mV at 25 °C versus the Ag/AgCl reference. The ORP mV versus a SHE would be 675 mV, add 205 mV to the observed value.

12.2.2. Rel. mV Calibration Procedure

1. Tap **Calibrate** and the meter will open a Rel. mV calibration screen.

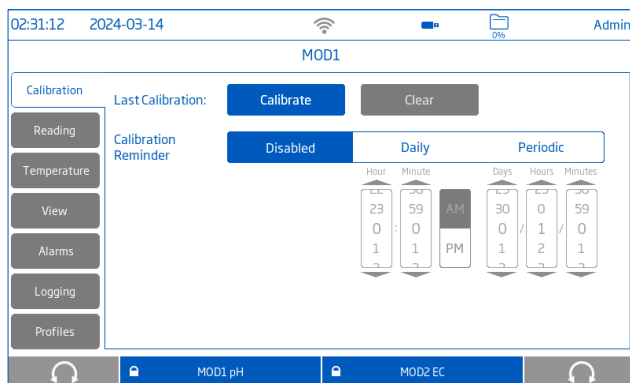

2. Place ORP electrode tip into a beaker of standard or a sample with known value.
[HI7021](#) (ORP solution for platinum and gold electrodes) reads 240 mV at 25 °C.
[HI7022](#) (ORP solution for platinum and gold electrodes) reads 470 mV at 25 °C.

3. Tap the Relative mV box value.

03:43:34 2024/06/11 Admin

Calibrate Rel.mV

Absolute mV: 470.2 mV

Relative mV: 675.0 mV

Press "Save" to update Rel mV.

Clear Calibration Cancel Save

MOD1 DO MOD2 EC MOD3 pH/ISE

4. Use the keypad to enter the value.

5. Tap  to confirm.

6. Tap **Save** to update the calibration and return to the measurement screen.

12.3. ORP MEASUREMENT

12.3.1. Measurement Tips

- Connect the electrode to be used to the appropriate meter input.
Make sure the electrode has been recently calibrated and is working correctly.
- Place electrode into the [HI764060](#) electrode holder for easy transfer in and out of containers during calibration, sample measurement, and storage.
- Rinse with purified water between buffers and/or samples.
- Blot (never rub!) the sensor with a lint-free tissue between buffers and samples.
- To limit sample contamination, pour two beakers of buffers and samples.
Use one beaker to rinse the sensor and the second for measurement.

Note: Use the same size beaker and immersion depth for samples and buffers.



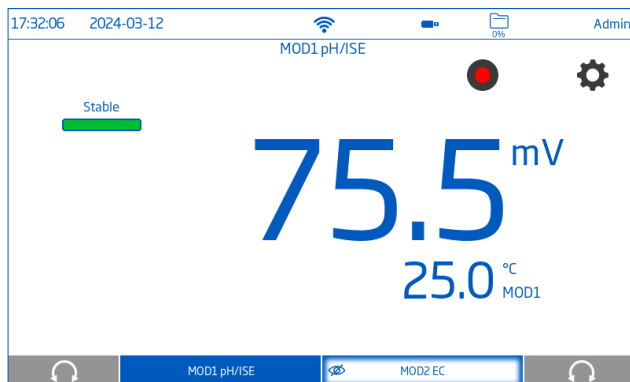

- Gently stir the test sample to ensure the sensor is measuring a representative sample.
- Open the fill hole cover and keep the fill solution topped off to permit the fill solution to flow through the ceramic junction and maintain a stable reference signal.
- If measuring across a temperature gradient, allow the sensor to reach thermal equilibrium.
- Once the reading indicates Stable, record measurement data.
- When all samples have been measured, rinse the electrode and replace storage cap with storage solution.
Replace fill hole cover.

12.3.2. Direct Readings

- Place the electrode tip and the temperature probe approximately 4 cm (1.5") into the sample to be measured. Allow time for the electrode to stabilize.
-  is displayed until measurement is stabilized.
- The measured mV/Rel mV value is displayed on the LCD.



12.3.3. Direct/Autohold Readings

- Place the electrode tip and the temperature probe approximately 4 cm (1.5") into the sample to be tested.
- Tap  to enable the autohold reading mode.
- The measured parameter value will be displayed on the LCD.
-  is displayed blinking.
- Once the stability criteria is reached the measured value is frozen on the display.
-  stops blinking.
- Tap  to release the autohold and return to direct reading mode.

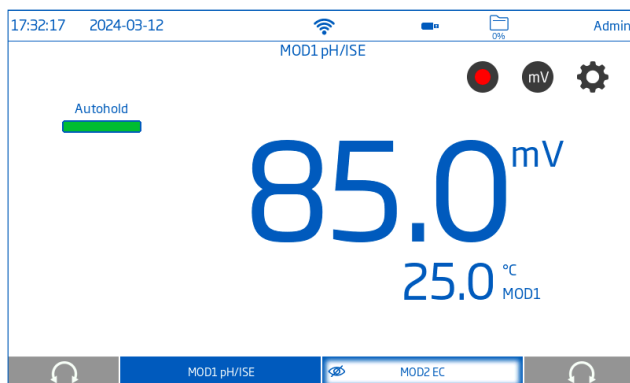

13. ISE MEASUREMENTS

13.1. MEASUREMENT SETTINGS

Connect ISE electrode to BNC connector on rear of meter.

Tap  from the measurement screen then select the **Reading** tab.

Set the parameter to ISE.



13.1.1. Calibration

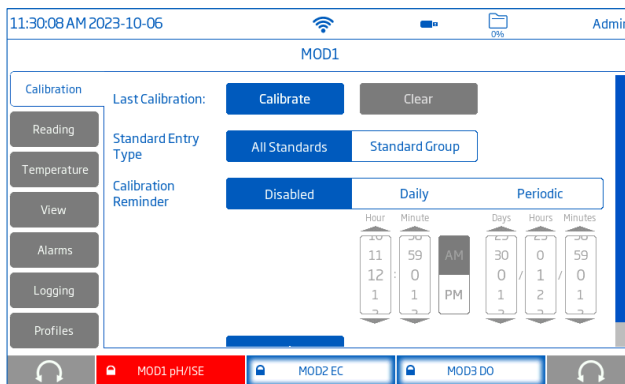

Last Calibration

Options: **Calibrate**, **Clear**

- **Calibrate**: starts a new user calibration.
- **Clear**: deletes the electrode calibration for the selected hardware module.
A calibration is required for ISE measurements.

Standard Entry Type

Options: **All Standards**, **Standard Group**

- **All Standards**: the user manually selects the standard value from all available predefined and custom standards.
- **Standard Group**: the user manually selects standard value from a group of standards.

Calibration Reminder

Options: **Disabled, Daily, Periodic**

- **Daily:** set the time of day the calibration reminder needs to be displayed.
 - **Periodic:** schedule time in days, hours and/or minutes after the last calibration for the calibration reminder to be displayed.
- “Calibrate probe” message is displayed after the calibration reminder period has elapsed.

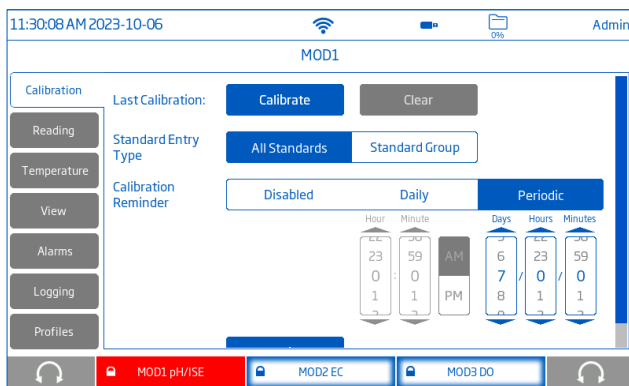

Standard Group

The standard group is used during calibration when **Standard Group** entry type is selected. During calibration the user can select the standard from the predefined group that matches the sample being measured. See section [13.2. ISE Calibration](#) for details.

13.1.2. Reading



Parameter

Options: **pH, mV, Rel. mV, ISE (HI6000-2 only)**

Tap to select desired measurement configuration.

Significant Digits

Options: **X, XX, XXX**

Tap to select the number of significant digits that should be displayed.

Stability Criteria

Options: **Accurate, Medium, Fast**



- **Accurate:** for applications where high accuracy is required.
A measurement is recognized as stable using more critical criteria evaluating measurement fluctuations.
- **Medium:** for applications where average accuracy is accepted.
A measurement is recognized as stable using less critical criteria evaluating measurement fluctuations.
The measurement may still change after registering stable.
- **Fast:** for applications where speed of delivery has priority.

While the measurement is changing, the stability indicator is shown partially (.

When the criteria is reached the indicator is displayed as a full green bar (.

Reading Mode

Options: **Direct, Direct/Autohold, Known Addition, Known Subtraction, Analyte Addition, Analyte Subtraction**

- **Direct:** as measurement changes measurement stability is continuously evaluated.
"Unstable" (blinking) or "Stable" is displayed above the stability indicator.
- **Direct/AutoHold:** measurements are initiated using the  icon.
When the measurement is stable it is frozen on the display.
The  icon is used to release the autohold reading.

Incremental Methods

- **Known Addition:** a known volume of standard is added to the sample after the initial readings.
The difference is used to calculate the concentration of the ion in the original sample.
- **Known Subtraction:** a known volume of standard is added to the sample after the initial readings.
The standard reacts with the sample reducing the concentration.
The difference is used to calculate the concentration of the ion in the original sample.
- **Analyte Addition:** a known volume of sample is added to the standard after the initial readings.
The difference is used to calculate the concentration of the ion in the sample.
- **Analyte Subtraction:** a known volume of sample is added to the standard after the initial readings.
The sample reacts with the standard reducing the concentration.
The difference is used to calculate the concentration of the ion in the sample.

Concentration Unit

Options: **ppt, ppm, ppb, g/L, mg/L, μ g/L, mg/mL, μ g/mL, M, mol/L, mmol/L, %w/v, User (custom unit)**
Select the desired concentration unit for the measured ion or chemical compound.

Electrode Type

Options: **Ammonia, Bromide, Cadmium, Calcium, Carbon Dioxide, Chloride, Cupric, Cyanide, Fluoride, Iodide, Lead, Nitrate, Potassium, Silver, Sodium, Sulfide, Custom**

- Select the ISE type from the list of predefined electrodes.
- Alternatively, opt to define a custom electrode. Five custom electrodes are available.

Molar Weight

Options: **0.001 to 1000.000 g/mol**

The molar weight for predefined electrodes is entered automatically and can not be changed.

For custom electrodes the molar weight needs to be entered.

Electric Charge/Slope

Options: **None / -59.16, 1 / 59.16, 2 / 29.58, -1 / -59.16, -2 / -29.58**

For predefined electrodes the electric charge and slope is entered preselected and can not be changed.

For custom electrodes the electric charge and slope need to be selected.

Electrode Name (Custom Electrodes Only)

Options: **up to 15 characters**

A name can be entered for custom electrodes.

13.1.3. Temperature

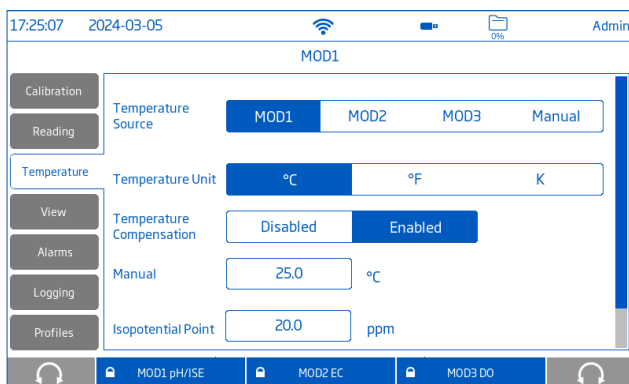

Temperature Source

Options: **Automatic (MOD1, MOD2 or MOD3), Manual**

User can select between physical temperature input source (MOD1, MOD2, MOD3) or entering sample temperature value manually.

- **Automatic** (with temperature probe): the temperature source is displayed next to the temperature measurement on the ISE display.
- **Manual** (without temperature probe): manual is displayed next to the temperature measurement on the measurement screen. Sample temperature needs to be entered.

Temperature Unit

Options: **°C, °F, K**

Tap to select the temperature unit.

Temperature Compensation

Options: **Disabled, Enabled**

The ISE calibration and measurement can be performed with temperature compensation.

When the temperature compensation option is enabled, the isopotential point of the electrode must be entered.

If enabled, ATC is displayed next to the temperature reading.

Manual

Options: **-20.0 to 120°C (-4.0 to 248.0 °F, 253.2 to 393.2 K)**

To manually input the temperature value:

1. Select temperature unit.
2. Tap the Manual input field.
3. Enter temperature value.
4. Tap  to confirm.

Isopotential Point

Options: **Vary** based on concentration unit

The isopotential point is the point at which temperature has no effect on the readings.

The isopotential point can be entered when temperature compensation is enabled.

To change the isopotential point:

1. Tap the isopotential point input field.
2. Enter isopotential point.
3. Tap  to confirm.

User Temperature Calibration

Options: **Calibrate, Clear**

- **Calibrate:** starts a new user calibration.
- **Clear:** deletes the temperature calibration for the selected hardware module.

To perform a new calibration:

1. Tap **Calibrate**.
2. Place the temperature probe and a reference thermometer with 0.1 resolution into a stirred container of water. Allow for the reading to stabilize.
3. If the displayed value is different than the reference thermometer reading, tap **Calibrated Temperature** value.
4. Use the on-screen keypad to edit.
5. Tap **Save** to confirm and save data.

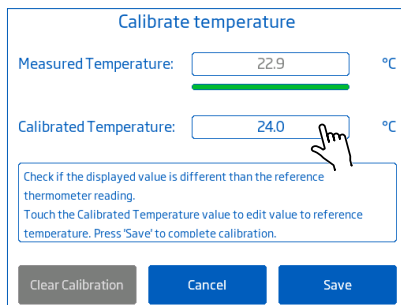

Calibrate temperature

Measured Temperature: °C

Calibrated Temperature: °C

Check if the displayed value is different than the reference thermometer reading.
Touch the Calibrated Temperature value to edit value to reference temperature. Press 'Save' to complete calibration.

Clear Calibration Cancel Save

13.1.4. View

Options: **Basic**, Simple GLP, Full GLP, Table

See section [9.1. View](#) for details.

When Known Addition, Known Subtraction, Analyte Addition, or Analyte Subtraction is selected, meter will automatically default to Basic view.

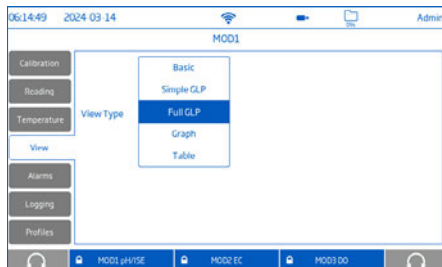

13.1.5. Alarms

Options: **High ISE**, Low ISE, High Temperature, Low Temperature

See section [9.2. Alarms](#) for details.



13.1.6. Logging

Options: **Automatic**, Manual, Autohold

See section [9.3. Logging](#) for details.

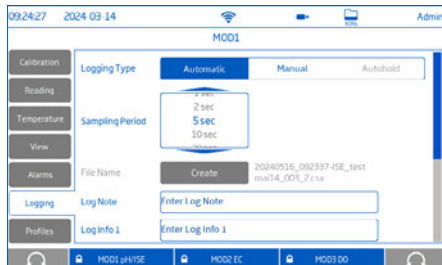

13.1.7. Profiles

See section [9.4. Profiles](#) for details.



13.2. ISE CALIBRATION

13.2.1. Calibration Guidelines



- Pour small quantities of the standard solutions into clean beakers. If possible, use plastic beakers to minimize any EMC interferences. For accurate calibration and to minimize cross-contamination, use two beakers for each standard solution, one for rinsing the electrode and one for calibration.
- The ISE calibration and measurement can be performed without temperature compensation. Standards and samples should be at the same temperature.
- Before calibrating, make sure that the **Electrode Type** has been selected in measurement settings according to the measured ion/compound.
- To read concentration (not activity!), ISA must be added to the standards and samples. No corrections are needed due to dilutions.
- Many ISE electrodes benefit from soaking the sensing tip in standard before calibrating. Consult the ISE manual for additional details.
- At least a two-point ISE calibration must be performed to establish the electrode slope.
- Select standards that are in the measurement range of the samples.

13.2.2. ISE Calibration Type

- **All Standards:** user can select from all predefined and custom standards during calibration.
- **Standard Group:** a group of predefined and custom standards can be selected from during calibration.

13.2.3. Standard Group

In addition to selecting from seven standard options, users can define five custom standards for calibration. To move standards from **Available Standards (Available Custom Standards)** trays to **Standards in Use** trays:

1. Tap .
2. Tap **Calibration** tab.
3. Tap **Edit** next to **Standard Group** item.
4. Tap to select from the **Available Standards** or **Available Custom Standards** trays. A rectangular outline highlights the standard value selected for transfer. For custom values, tap an empty tray to input a new value or an existing tray to edit the standard value. Follow the Editing Custom Standard Values steps.
5. Tap  to move the selected standard in the **Standards in Use** column.
 -  displayed next to the standard value indicates calibration with standard solution.
 -  displayed next to the standard value indicates calibration with custom solution.

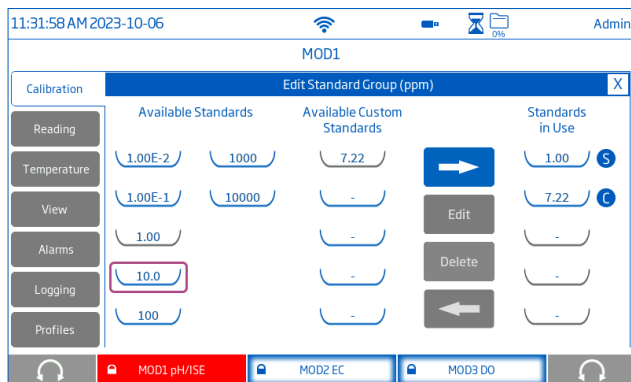

6. Repeat with up to five standards.

Editing Custom Standards Values

1. Tap a custom standard tray from the **Available Custom Standards** column.
2. Tap **Edit**.
3. Use the numeric keypad to enter a value.
4. Tap  to confirm.

13.2.4. ISE Calibration

With the electrode and temperature sensor connected to the meter:

1. Remove the protective cap from the electrode and rinse the electrode with purified water.
2. Fill a rinse beaker 2/3 full with the lowest concentration standard first.
3. Swirl the electrode and temperature sensor in the standard solution.
4. Raise and lower the electrode several times. Discard the solution.
5. Fill the calibration beaker 2/3 full with the same standard solution.
6. Slowly place the electrode and temperature sensor in the selected standard.
Dislodge bubbles that may adhere to the sensors.
7. If using a new ISE electrode, tap **Clear Calibration** to clear all standards and start new.
8. Use the arrows under the standard tray to select the standard value from all predefined and custom standards.

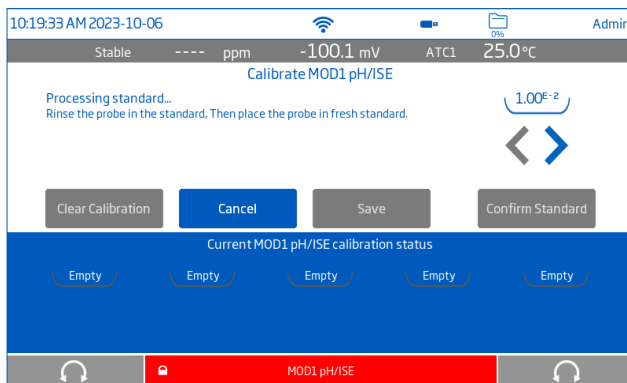
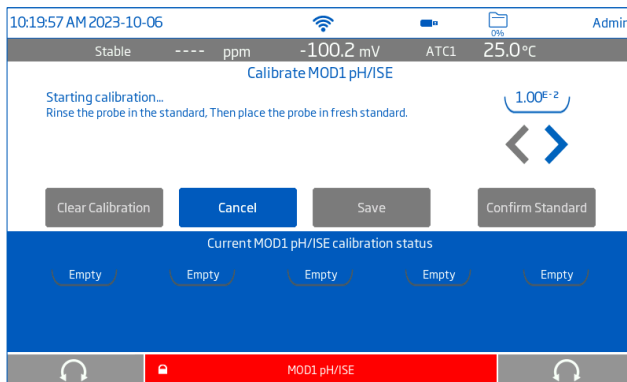

9. Wait for the reading to stabilize.
10. Tap **Confirm Standard** to save the calibration point and move to the next standard.
Repeat procedure for a total of five calibration points (if needed).

11. Tap **Save** to update the calibration and return to the measurement screen.

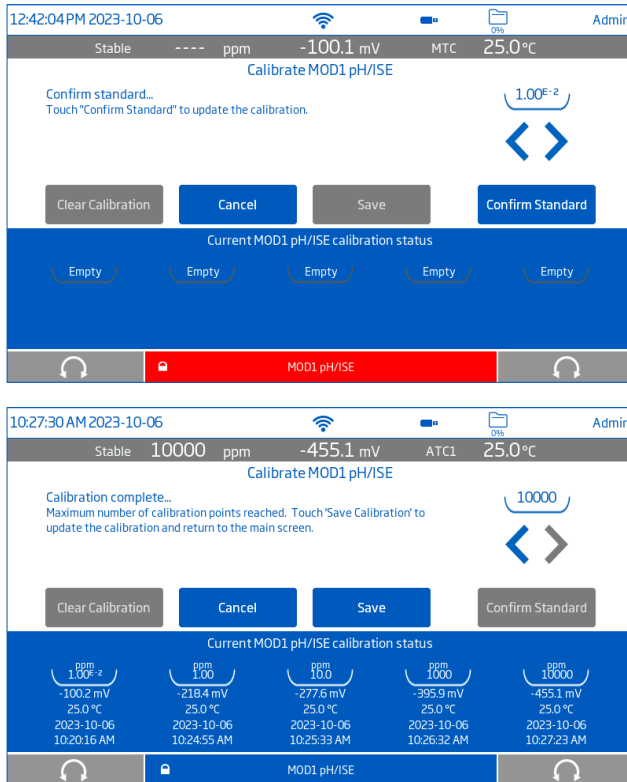

13.2.5. Calibration Messages

- **Standard can't be accepted**

The current standard was already used or is too close to a standard that has been used. Choose a new standard.

- **Calibration inconsistency**

The current standard is generating a slope over the of acceptable window. Check the standard value and use fresh solution.

- **Invalid reading**

The current standard is generating a slope outside of the acceptable window. Check the selected standard value and use fresh solution.

13.3. ISE MEASUREMENT

13.3.1. ISE Measurement Tips

- Connect the electrode to be used to the appropriate meter input.
- Make sure the electrode has been recently calibrated and is working correctly.

Note: A two point calibration is required when using incremental methods.

- Place electrode into the [HI764060](#) electrode holder for easy transfer in and out of containers during calibration, sample measurement, and storage.
- Rinse with purified water between standards and/or samples.
- Blot (never rub!) the sensor with a lint-free tissue between standards and samples.
- To limit sample contamination, pour two beakers of standards and samples. Use one beaker to rinse the sensor, and then use the second for measurement.



Note: Use the same size beaker, immersion depth, and stir rate for samples and standards.

- Gently stir the test sample to ensure the sensor is measuring a representative sample.
- Open the fill hole cover and keep the fill solution topped off to permit the fill solution to flow through the junction and maintain a stable reference signal.
- Measure standards and samples at same temperatures. If using manual temperature compensation, input the sample temperature.
- Once the reading indicates "Stable", record measurement data.
- When all samples have been measured, rinse the electrode and replace storage cap.
- Add the appropriate ISA (Ionic Strength Adjuster) to both samples and standards. Consult ISE manual for sensor preparation details.

13.3.2. Direct Readings

- Place the electrode tip and the temperature probe approximately 4 cm (1.5") into the sample to be measured. Allow time for the electrode to stabilize.
- Unstable status indicator () is displayed until measurement is stabilized.
- The measured ISE value is displayed on the LCD.

13.3.3. Direct / Autohold Readings

- Place the electrode tip and the temperature probe approximately 4 cm (1.5") into the sample to be tested.
- Tap  to enable the autohold reading mode.
- The measured parameter value will be displayed. Autohold status indicator () is displayed blinking.
- Once the stability criteria is reached, the measured value is frozen on the display. Autohold status indicator () stops blinking.

- Tap **ISE** to release the autohold and return to direct reading mode.

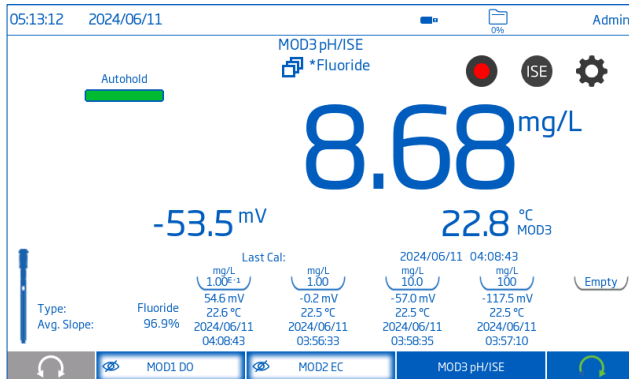

13.3.4. Known Addition

Note: Before starting a Known Addition analysis determine what sample volume, standard concentration, and standard volume will produce the best results.

As a general rule, the addition of standard should change the mV value of the sample by 15 to 20 mV.

- For a positively charged ion (e.g. Sodium, Potassium, Calcium), the standard addition should increase the mV.
- For a negatively charged ion (e.g. Sulfide, Fluoride, Chloride), the standard addition should decrease the mV.

Start with a small trial.

For example:

1. Measure 50 mL of sample and add a magnetic stir bar.
2. Place measured sample on a stirrer and add ISA.
Consult ISE manual.
3. Place ISE electrode tip into the sample.
4. Put instrument in mV mode and record the observed mV.
5. Use a micropipette to add a volume of the highest ISE standard available (e.g. 0.1M or 1000 ppm).
Start by adding, for example, 500 μ L at a time.
6. Monitor the change in mV.
7. When \sim 15 mV change from the original sample has been noted, calculate the total volume added.
8. Adjust sample and standard volumes proportionally to standard volumes that can be measured with accuracy.
Use volumetric pipettes for standard, ISA, and sample addition.

- Tap **Start KA** to start the Known Addition method.

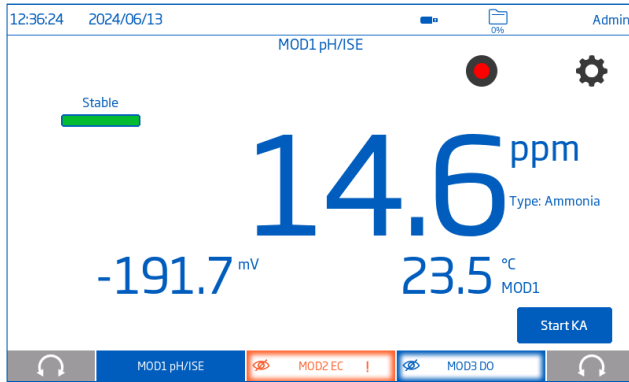

- Edit the Sample Volume, ISA Volume, Standard Volume, and Standard Concentration.
- Tap **Start** to begin.



- Add specified quantity of ISA to specified volume of sample.
- Immerse the electrode in the sample. Tap **Continue**.

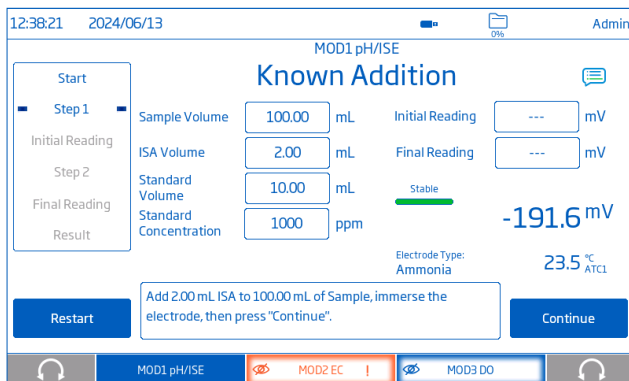

- The Initial Reading value is displayed. Once the measurement has stabilized the **Accept** button is active. Tap **Accept** to save the reading.

12:39:39 2024/06/13 Admin

MOD1 pH/ISE

Known Addition

Start

Step 1

Initial Reading

Step 2

Final Reading

Result

Sample Volume 100.00 mL

Initial Reading --- mV

ISA Volume 2.00 mL

Final Reading --- mV

Standard Volume 10.00 mL

Standard Concentration 1000 ppm

Stable

-191.6 mV

Electrode Type: Ammonia 23.5 °C ATCL

Press "Accept" to save current reading.

Restart Accept

MOD1 pH/ISE MOD2 EC MOD3 DO

- Add specified volume of Standard into the sample.
- Tap **Continue**.

12:42:32 2024/06/13 Admin

MOD1 pH/ISE

Known Addition

Start

Step 1

Initial Reading

Step 2

Final Reading

Result

Sample Volume 100.00 mL

Initial Reading -191.6 mV

ISA Volume 2.00 mL

Final Reading --- mV

Standard Volume 10.00 mL

Standard Concentration 1000 ppm

Stable

-250.5 mV

Electrode Type: Ammonia 23.5 °C ATCL

Add 10.00 mL of 1000 ppm Standard into the sample then press "Continue".

Restart Continue

MOD1 pH/ISE MOD2 EC MOD3 DO

- The Final Reading value is displayed. Once the measurement has stabilized the **Accept** button is active. Tap **Accept** to save the reading.

12:43:35 2024/06/13 Admin

MOD1 pH/ISE

Known Addition

Start

Step 1

Initial Reading

Step 2

Final Reading

Result

Sample Volume 100.00 mL

Initial Reading -191.6 mV

ISA Volume 2.00 mL

Final Reading --- mV

Standard Volume 10.00 mL

Standard Concentration 1000 ppm

Stable

-250.4 mV

Electrode Type: Ammonia 23.5 °C ATCL

Press "Accept" to save current reading.

Restart Accept

MOD1 pH/ISE MOD2 EC MOD3 DO

- The ISE measurement result is displayed.
- Tap **Save** to save the final result and generate a log report.

10:36:41 AM 2023-10-06 Admin

MOD1 pH/ISE

Known Addition

Start

Step 1

Initial Reading

Step 2

Final Reading

Result

Sample Volume: 100.00 mL

Initial Reading: -316.8 mV

ISA Volume: 2.00 mL

Final Reading: -397.1 mV

Standard Volume: 10.00 mL

Standard Concentration: 100 ppm

4.18E-1 ppm

Electrode Type: Ammonia

The sample was found to have 4.18E-1 ppm

Restart Save

MOD1 pH/ISE MOD2 EC

13.3.5. Known Subtraction

Note: Before starting a Known Subtraction analysis determine which sample volume, standard reactant concentration, and standard volume will produce the best results.

Determine the way the reagent will react with the measured ion on a molar basis (stoichiometric factor).

As a general rule, the addition of standard should change the mV value of the sample by 15 to 20 mV for a monovalent ion (e.g. Fluoride, Chloride) or 5 to 10 mV for a divalent ion (e.g. Calcium).

- For a positively charged ion (e.g. Calcium), the reactant addition should decrease the mV.
- For a negatively charged ion (e.g. Sulfide, Chloride), the reactant addition should increase the mV.

Start with a small trial.

For example:

1. Measure 50 mL of sample and add a magnetic stir bar.
2. Place measured sample on a stirrer and add ISA.
Consult ISE manual.
3. Place ISE electrode tip into the sample.
4. Put instrument in mV mode and record the observed mV.
5. Use a micropipette to add a volume of the reactant standard.
Start by adding, for example, 500 μ L at a time.
6. Monitor the change in mV.
7. When ~ 15 mV change from the original sample has been noted, calculate the total volume added.
8. Adjust sample and standard volumes proportionally to standard volumes that can be measured with accuracy.
Use volumetric pipettes for standard, ISA, and reagent addition.

- Tap **Start KS** to start the Known Subtraction method.

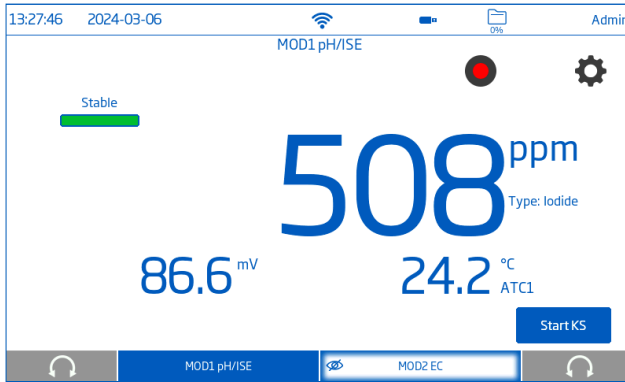

- Edit Sample Volume, ISA Volume, Reagent Volume, Reagent Concentration, and Stoichiometric Factor.
- Tap **Start** to begin.

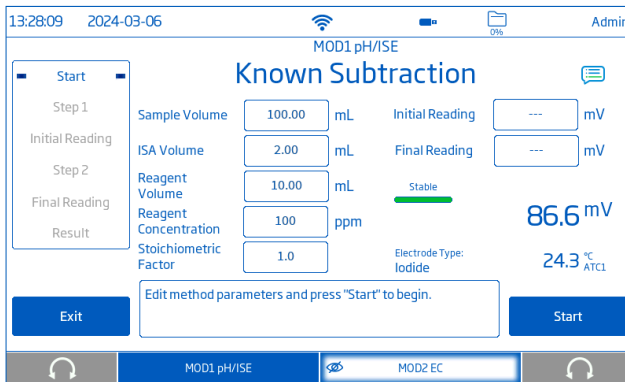

- Add specified amount of ISA to specified volume of sample.
- Immerse the electrode in the sample and tap **Continue**.

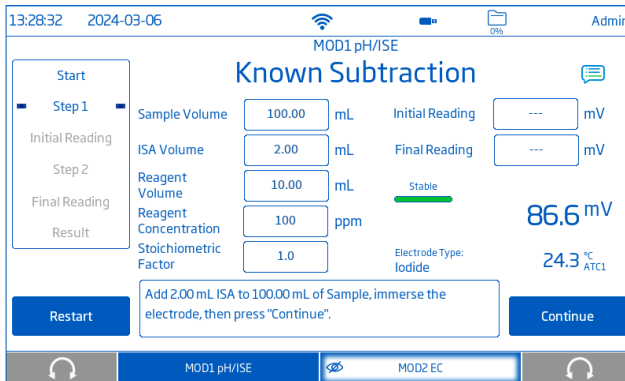

- The Initial Reading value is displayed. Once the measurement has stabilized the **Accept** button is active. Tap **Accept** to save the reading.

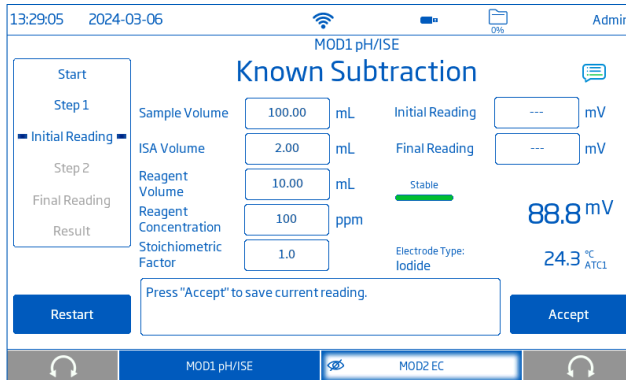

- Add specified volume of reagent into the sample. Tap **Continue**.

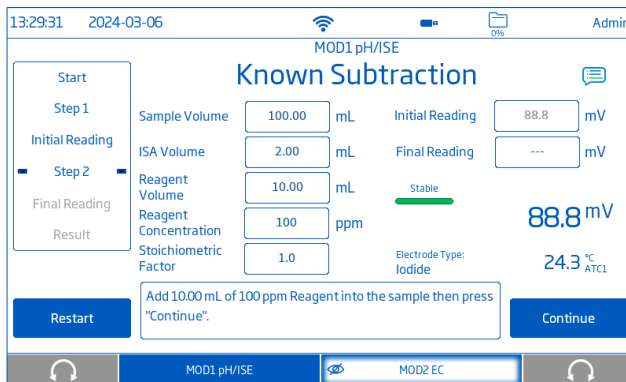

- The Final Reading value is displayed. Once the measurement has stabilized the **Accept** button is active. Tap **Accept** to save the reading.

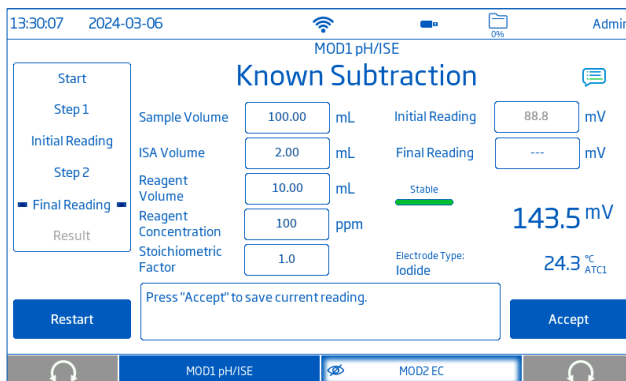

- The ISE measurement result is displayed.
- Tap **Save** to save the final result and generate a log report.

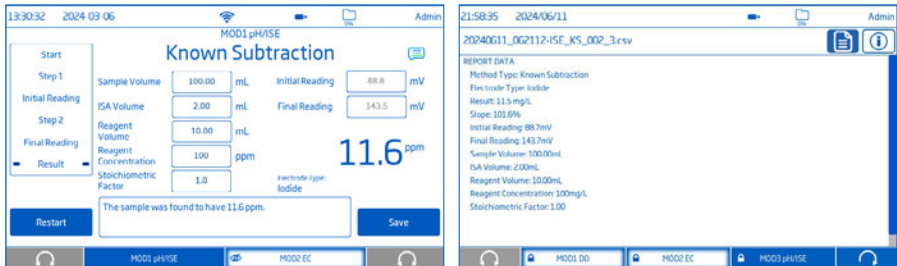

13.3.6. Analyte Addition

Note: Before starting an Analyte Addition analysis determine which standard volume, concentration, and sample size will produce the best results.

As a general rule, the standard must be less concentrated than the sample so the addition of sample will increase the total ion content of the solution from the beaker; and change the mV value by at least 10 mV.

- For a positively charged ion (e.g. Sodium) the AA increases the mV.
- For a negatively charged ion (e.g. Sulfide, Fluoride, Chloride) the AA should decrease the mV.

Start with a small trial.

For example:

1. Measure 50 mL of standard and add a magnetic stir bar.
2. Place measured standard on a stirrer and add ISA.
Consult ISE manual.
3. Place ISE electrode tip into the sample.
4. Put instrument in mV mode and record the observed mV.
5. Use a micropipette to add a volume of the sample.
Start by adding, for example, 500 μ L at a time.
6. Observe the change in mV.
7. When ~ 10 mV change from the original standard has been noted, calculate the total volume added.
8. Adjust sample and standard volumes proportionally to standard volumes that can be measured with accuracy.
Use volumetric pipettes for standard, ISA, and sample addition.

- Tap **Start AA** to start the Analyte Addition method.

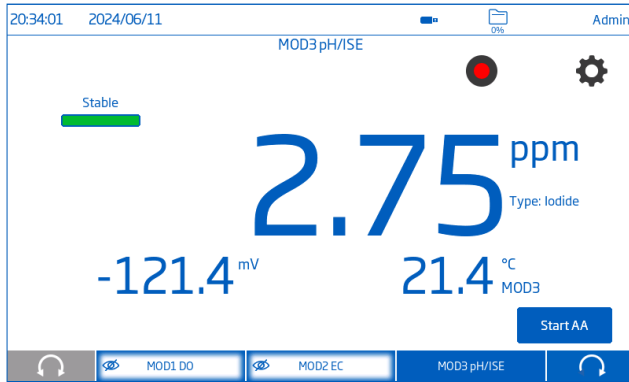

- Edit Standard Volume, Standard Concentration, ISA Volume, and Sample Volume.
- Tap **Start** to begin.

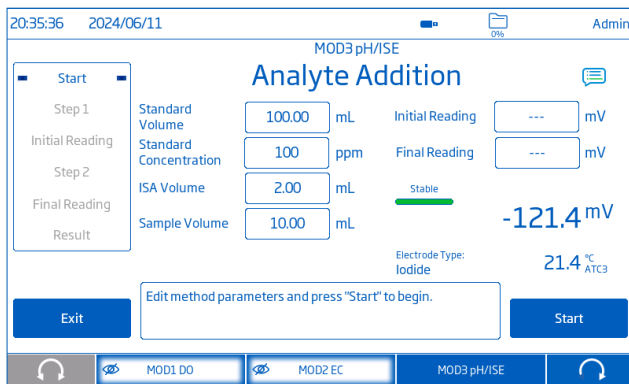

- Add specified amount of ISA to specified volume of Standard.
- Immerse the electrode in the sample and tap **Continue**.

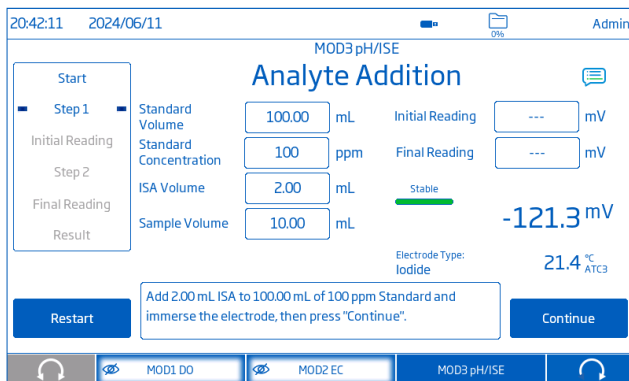

- The Initial Reading value is displayed. Once the measurement has stabilized the **Accept** button is active. Tap **Accept** to save the reading.

20:42:40 2024/06/11 Admin

MOD3 pH/ISE

Analyte Addition

Start

Step 1

Initial Reading

Step 2

Final Reading

Result

Standard Volume: 100.00 mL

Standard Concentration: 100 ppm

ISA Volume: 2.00 mL

Sample Volume: 10.00 mL

Initial Reading: -121.3 mV

Final Reading: -121.3 mV

Stable

-121.3 mV

Electrode Type: Iodide

21.4 °C ATC3

Press "Accept" to save current reading.

Restart Accept

MOD1 DO MOD2 EC MOD3 pH/ISE

- Add specified volume of sample into the Standard. Tap **Continue**.

20:44:00 2024/06/11 Admin

MOD3 pH/ISE

Analyte Addition

Start

Step 1

Initial Reading

Step 2

Final Reading

Result

Standard Volume: 100.00 mL

Standard Concentration: 100 ppm

ISA Volume: 2.00 mL

Sample Volume: 10.00 mL

Initial Reading: -121.3 mV

Final Reading: -156.2 mV

Stable

-156.2 mV

Electrode Type: Iodide

21.4 °C ATC3

Add 10.00 mL of Sample into the Standard, then press "Continue".

Restart Continue

MOD1 DO MOD2 EC MOD3 pH/ISE

- The Final Reading value is displayed. Once the measurement has stabilized the **Accept** button is active. Tap **Accept** to save the reading.

20:44:48 2024/06/11 Admin

MOD3 pH/ISE

Analyte Addition

Start

Step 1

Initial Reading

Step 2

Final Reading

Result

Standard Volume: 100.00 mL

Standard Concentration: 100 ppm

ISA Volume: 2.00 mL

Sample Volume: 10.00 mL

Initial Reading: -121.3 mV

Final Reading: -156.2 mV

Stable

-156.2 mV

Electrode Type: Iodide

21.4 °C ATC3

Press "Accept" to save current reading.

Restart Accept

MOD1 DO MOD2 EC MOD3 pH/ISE

- The ISE measurement result is displayed.
- Tap **Save** to save the final result and generate a log report.

20:45:36 2024/06/11 Admin

MOD3 pH/ISE

Analyte Addition

Start

Step 1

Initial Reading

Step 2

Final Reading

Result

Standard Volume: 100.00 mL

Initial Reading: -121.3 mV

Standard Concentration: 100 ppm

Final Reading: -156.2 mV

ISA Volume: 2.00 mL

Sample Volume: 10.00 mL

3180 ppm

Electrode Type: Iodide

The sample was found to have 3180 ppm.

Save

Restart

MOD1 DO MOD2 EC MOD3 pH/ISE

20:48:16 2024/06/11 Admin

20240611_204556-ISE_AA_003_3.csv

REPORT DATA

Method Type: Analyte Addition

File Iodide Type: Iodide

Result: 3180 ppm

Slope: 103.6%

Initial Reading: -121.3mV

Final Reading: -156.2mV

Sample Volume: 10.00mL

ISA Volume: 2.00mL

Standard Volume: 100.00mL

Standard Concentration: 100ppm

MOD1 DO MOD2 EC MOD3 pH/ISE

20:46:49 2024/06/11 Admin

Name	Report Type	Module	Start/Stop	Result
20240611_062112-ISE_K5_002_3.csv	Known Subtraction	MOD3 pH/ISE	06:21:12-2024/06/11 04:04:05-2024/06/10	11.5 mg/L
20240611_204556-ISE_AA_003_3.csv	Analyte Addition	MOD3 pH/ISE	20:45:56-2024/06/11 04:04:05-2024/06/10	3180 ppm

MOD1 DO MOD2 EC MOD3 pH/ISE

13.3.7. Analyte Subtraction

Note: Before starting an Analyte Subtraction analysis determine which sample volume, reactant volume, and concentration will produce the best results.

Determine the way the reagent will react with the measured ion on a molar basis (stoichiometric factor) and what ISE standard will best follow the reaction.

As a general rule, the reactant should contain the measured ion so the sample addition will react with the ion and reduce the measured concentration of the sample.

The change of the mV value, before and after the sample addition, should be at least 10 mV.

Start with a small trial.

For example:

1. Measure 50 mL of reactant and add a magnetic stir bar .
2. Place measured reactant on a stirrer and add ISA (consult ISE manual).
3. Place ISE electrode tip into the sample.
4. Put instrument in mV mode and record the observed mV.
5. Use a micropipette to add a volume of the sample.
Start by adding, for example, 500 μL at a time.
6. Observe the change in mV.
7. When ~ 10 mV change from the original value has been noted, calculate the total volume added.
8. Adjust sample and standard volumes proportionally to standard volumes that can be measured with accuracy.
9. Use volumetric pipettes for standard, ISA, and sample addition.

Note that in the following example the unknown sample contains chloride ions.

The reaction is being followed with a HI4115 silver ISE.

Calibrate the electrode before procedure is started.

Silver ions react with chloride ions to form silver chloride with a reaction primarily with 1:1 stoichiometry.

- Tap **Start AS** to start the Analyte Subtraction method.

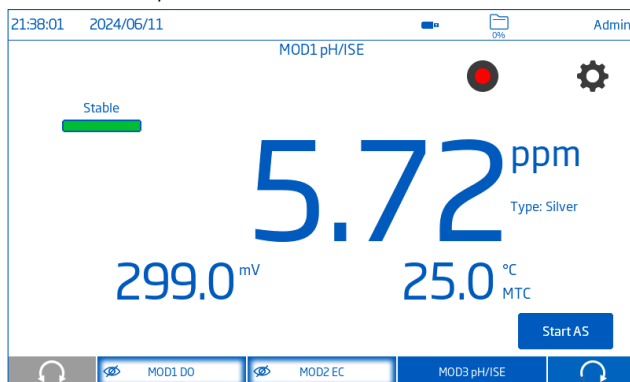

- Edit Reagent Volume, Reagent Concentration, ISA Volume, Stoichiometric Factor, and Sample Volume.

- Tap **Start** to begin.

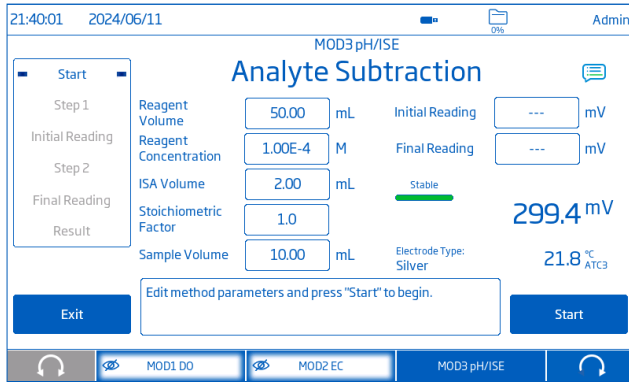

- Add specified amount of ISA to specified volume of Reagent.
- Immerse the electrode in the sample. Tap **Continue**.

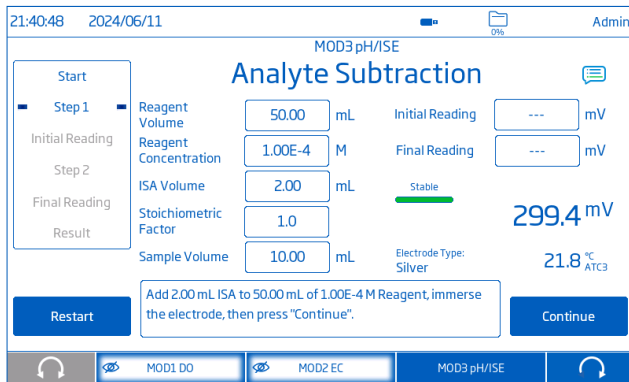

- The Initial Reading value is displayed. Once the measurement has stabilized the **Accept** button is active. Tap **Accept** to save the reading.

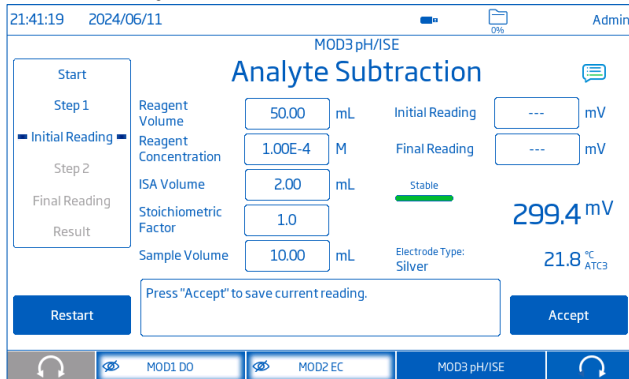

- Add specified volume of Sample into the Reagent.
- Tap **Continue**.

21:41:52 2024/06/11 Admin

MOD3 pH/ISE

Analyte Subtraction

Start	Reagent Volume	50.00 mL	Initial Reading	299.4 mV
Step 1	Reagent Concentration	1.00E-4 M	Final Reading	---
Initial Reading	ISA Volume	2.00 mL	Stable	
Step 2	Stoichiometric Factor	1.0	299.4 mV	
Final Reading	Sample Volume	10.00 mL	Electrode Type:	21.8 °C ATC3
Result			Silver	

Restart

Add 10.00 mL of Sample into the Reagent, then press "Continue".

Continue

- The Final Reading value is displayed. Once the measurement has stabilized the **Accept** button is active. Tap **Accept** to save the reading.

21:44:18 2024/06/11 Admin

MOD3 pH/ISE

Analyte Subtraction

Start	Reagent Volume	50.00 mL	Initial Reading	299.4 mV
Step 1	Reagent Concentration	1.00E-4 M	Final Reading	---
Initial Reading	ISA Volume	2.00 mL	Stable	
Step 2	Stoichiometric Factor	1.0	269.3 mV	
Final Reading	Sample Volume	10.00 mL	Electrode Type:	21.8 °C ATC3
Result			Silver	

Restart

Press "Accept" to save current reading.

Accept

- The ISE measurement result is displayed.
- Tap **Save** to save the final result and generate a log report.

21:45:32 2024/06/11 Admin

MOD3 pH/ISE

Analyte Subtraction

Start

Step 1

Reagent Volume: 50.00 mL

Initial Reading: 299.4 mV

Reagent Concentration: 1.00E-4 M

Final Reading: 269.2 mV

Step 2

ISA Volume: 2.00 mL

Stoichiometric Factor: 1.0

Sample Volume: 10.00 mL

Electrode Type: Silver

3.20E-4 M

The sample was found to have 3.20E-4 M.

Restart Save

MOD1 DO MOD2 EC MOD3 pH/ISE

21:46:39 2024/06/11 Admin

20240611_214547-ISE_AS_004_3.csv

REPORT DATA

Method Type: Analyte Subtraction

File Name: Silver

Result: 3.20E-4 M

Slope: 90.2%

Initial Reading: 299.4mV

Final Reading: 269.2mV

Sample Volume: 10.00mL

ISA Volume: 2.00mL

Reagent Volume: 50.00mL

Reagent Concentration: 1.00E-4M

Stoichiometric Factor: 1.00

MOD1 DO MOD2 EC MOD3 pH/ISE

21:46:09 2024/06/11 Admin

Name	Report Type	Module	Start/Stop	Result
20240611_062112-ISE_K5_002_3.csv	Known Subtraction	MOD3 pH/ISE	06:21:12-2024/06/11 04:04:05-2024/06/11	11.5 mg/L
20240611_204356-ISE_AA_003_3.csv	Analyte Addition	MOD3 pH/ISE	20:43:56-2024/06/11 04:04:05-2024/06/11	3180 ppm
20240611_214547-ISE_AS_004_3.csv	Analyte Subtraction	MOD3 pH/ISE	21:45:47-2024/06/11 04:04:05-2024/06/11	3.20E-4 M

MOD1 DO MOD2 EC MOD3 pH/ISE

14. EC MEASUREMENTS

14.1. MEASUREMENT SETTINGS

Connect EC electrode to the connector on rear of meter.

Tap  from the measurement screen to view the measurement settings.

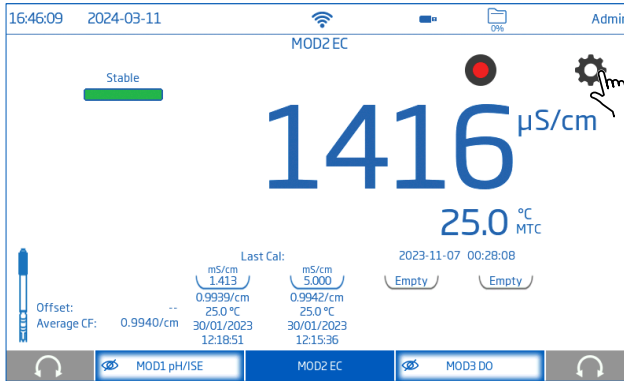

14.1.1. EC Calibration

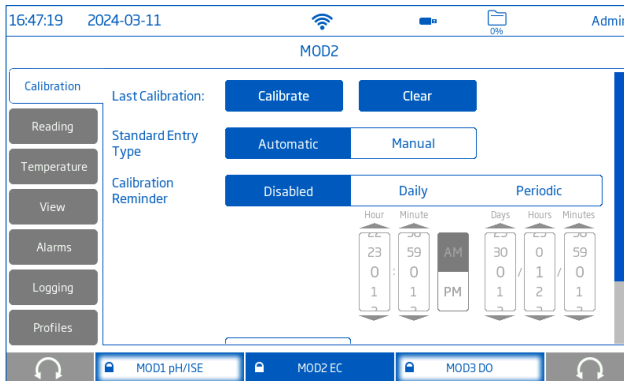

Last Calibration

Options: **Calibrate**, **Clear**

- **Calibrate**: starts a new user calibration.
- **Clear**: deletes the EC electrode calibration for the selected hardware module. A default calibration will replace the actual electrode calibration until a new calibration is made.

Standard Entry Type (Conductivity Only)

Options: **Automatic**, **Manual**

- **Automatic**: the meter selects the closest calibration standard to that of the sample being measured.
- **Manual**: the user manually enters the calibration standard to be used for calibration.

Calibration Reminder

Options: **Disabled, Daily, Periodic**

- **Daily:** set the time of day the calibration reminder needs to be displayed.
- **Periodic:** schedule time in days, hours and/or minutes after the last calibration for the calibration reminder to be displayed.
 “Calibrate probe” message is displayed on the screen after the calibration reminder period has elapsed.

Cell Constant (Conductivity Only)

Options: **0.0500 to 200.0000**

Allows users to adjust cell constant to a published cell-factor value or a different cell factor from another model.

1. Tap the **Cell Constant** input field.
2. Delete existing cell-constant value in the box.
3. Enter new value.
4. Select **Save** or tap  to confirm.

Calibration Points (Conductivity Only)

Options: **Single Point, Multiple Points**

- **Single Point:** calibration is done at one point
- **Multiple Points:** calibration is done at 0 μ S/cm to calibrate the offset and up to four additional standards for the cell factor.

14.1.2. Reading

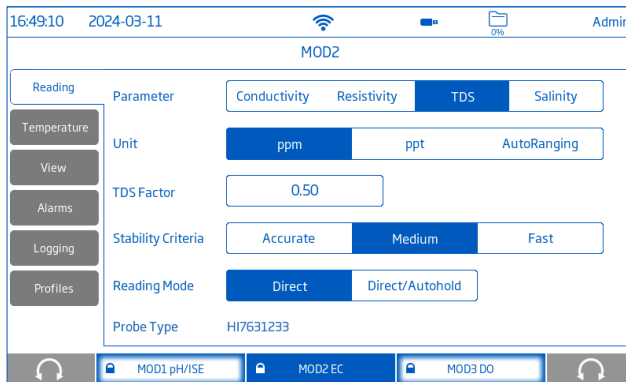

Parameter

Options: **Conductivity, Resistivity, TDS, Salinity**

Tap to select measurement configuration.

Unit

- **Conductivity**
 - $\mu\text{S}/\text{cm}$, mS/cm , AutoRanging
- **Resistivity**
 - $\Omega\cdot\text{cm}$, $\text{k}\Omega\cdot\text{cm}$, $\text{M}\Omega\cdot\text{cm}$, AutoRanging
- **TDS**
 - ppm, ppt, AutoRanging

Scale (Salinity only)

Options: **ppt** (Natural Sea Water Scale 1966), **PSU** (Practical Salinity Scale 1978), **%** (Hanna® Percent Scale)

Note: When autoranging is selected, the meter automatically selects the unit to optimize the measurement.

After choosing Salinity, the salinity scale must be chosen.

TDS Factor (TDS only)

Options: **0.40 to 1.00**

TDS factor is a conversion factor used to change an EC measurement to a TDS measurement.

To set the TDS factor:

1. Tap the **TDS factor** input field
2. Enter the TDS factor.
3. Tap  to confirm.

Stability Criteria

Options: **Accurate, Medium, Fast**





- **Accurate:** for applications where high accuracy is required.
A measurement is recognized as stable using more critical criteria evaluating measurement fluctuations.
- **Medium:** for applications where average accuracy is accepted.
A measurement is recognized as stable using less critical criteria evaluating measurement fluctuations.
The measurement may still change after registering stable.
- **Fast:** for applications where speed of delivery has priority.

While the measurement is changing, the stability indicator is shown partially ().

When the criteria is reached, the indicator is displayed as a full green bar ().

Reading Mode

Options: **Direct, Direct/Autohold, Direct/USP** (Conductivity Only)

- **Direct:** as measurement changes, measurement stability is continuously evaluated.
"Unstable" (blinking) or "Stable" is displayed above the stability indicator.
- **Direct/Autohold:** measurements are initiated using the  icon.
When the measurement is stable, it is frozen on the display.
Tap , , , or  to release the autohold reading.

- **Direct/USP:** used for conductivity measurements required to prepare water for injection (WFI) according to USP <645>.

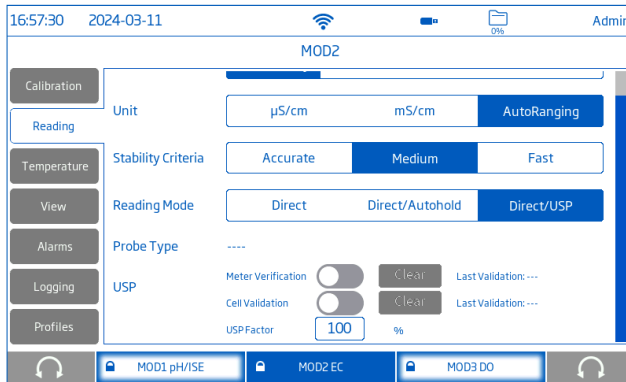

USP (Direct/USP Only)

Meter Verification: Disabled, Enabled

Cell Validation: Disabled, Enabled

USP Factor: 10 to 100%

Use the slider icon to enable or disabled meter verification or cell validation.

Note: Meter Verification and Cell Validation must be completed before evaluation of Stage 1 water. After completing, both options may be disabled. The previous validation is stored. They should be retested according to SOP schedules.

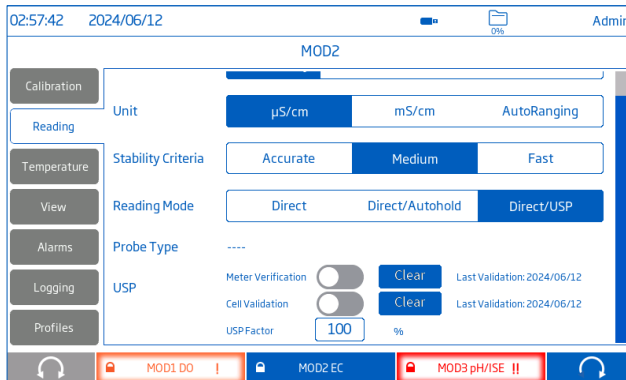

To set the USP factor:

1. Tap the **USP factor** input field.
2. Enter the USP factor.
3. Tap  to confirm.

14.1.3. Temperature

The screenshot displays the MOD2 configuration screen for temperature settings. At the top, it shows the time (16:51:46), date (2024-03-11), and user (Admin). The main area is titled 'MOD2' and contains several sections:

- Calibration**: A button to access calibration settings.
- Reading**: A button to view the current reading.
- Temperature Source**: A dropdown menu with options MOD1, MOD2 (selected), MOD3, and Manual.
- Temperature Unit**: A dropdown menu with options °C (selected), °F, and K.
- Temperature Compensation**: A dropdown menu with options Linear (selected), Natural, Standard, and Disabled.
- Manual**: A text input field containing '25.0' with a °C unit indicator.
- Reference Temperature**: A text input field containing '25.0' with a °C unit indicator.

At the bottom, there are three module selection buttons: MOD1 pH/ISE, MOD2 EC (selected), and MOD3 DO.

Temperature Source

Options: **Automatic (MOD1, MOD2, MOD3), Manual**

Users can select between physical temperature input source (MOD1, MOD2, MOD3) or entering sample temperature value manually.

- **Automatic**: built-in temperature sensor adjusts the measured conductivity to a reference temperature. ATC is displayed indicating temperature compensation status.
- **Manual**: sample temperature is entered manually. MTC is displayed indicating temperature compensation status.

Temperature Unit

Options: °C, °F, K

Users can select the temperature unit.

Temperature Compensation (Conductivity, Resistivity, TDS)

Options: **Linear, Natural, Standard, Disabled**

- **Linear**: is used when it is assumed that the temperature coefficient of variation has the same value for all measurement temperatures.
- **Natural**: for natural ground, well, or surface water (or water with similar composition) and covers 60 to 1000 $\mu\text{S}/\text{cm}$ from 0 to 35 °C in accordance with ISO7888 standard.
- **Standard**: is used for high-purity water measurements ($> 1 \text{ M}\Omega \cdot \text{cm}$ resistivity) and documented in ASTM Standard D5391-14.

Temperature Compensation (Salinity)

The temperature compensation is applied in accordance to the selected scale.

- ppt: applied according to the Natural Sea Water Scale 1966
- PSU: applied according to the Practical Scale 1978
- %: applied according to the Hanna[®] Percent Scale

Manual

Options: -20.0 to 120 °C (-4.0 to 248.0 °F, 253.2 to 393.2 K)

To manually input the temperature value:

1. Select the temperature unit.
2. Tap the Manual input field.
3. Enter temperature value.
4. Tap  to confirm.

Reference Temperature (Conductivity, Resistivity, TDS)

Options: 5.0 to 30 °C (41.0 to 86.0 °F, 278.2 to 303.2 K)

Value used for temperature-compensated conductivity. All conductivity measurements will be referenced to the conductivity of a sample at this temperature.

To manually input the reference temperature value:

1. Select the temperature unit.
2. Tap the **Reference Temperature** input field.
3. Enter temperature value.
4. Tap  to confirm.

Temperature Coefficient (Conductivity, Resistivity, TDS)

Options: 0.00 to 10.00 %/°C

Temperature coefficient is a function of the solution being measured. When the actual temperature coefficient of the sample is known:

1. Tap the **Temperature Coefficient** input field.
2. Enter temperature coefficient value.
3. Tap  to confirm.

User Temperature Calibration

Options: **Calibrate**, **Clear**

Calibrate: starts a new user calibration.

Clear: deletes the temperature calibration for the selected hardware module.

To perform a new calibration:

1. Tap **Calibrate**.
2. Place the probe and a reference thermometer with 0.1 resolution into a stirred container of water. Allow reading to stabilize.
3. If the displayed value is different than the reference thermometer reading, tap **Calibrated Temperature**. Use the on-screen keypad to enter the value.

4. Tap **Save** to confirm and save data.

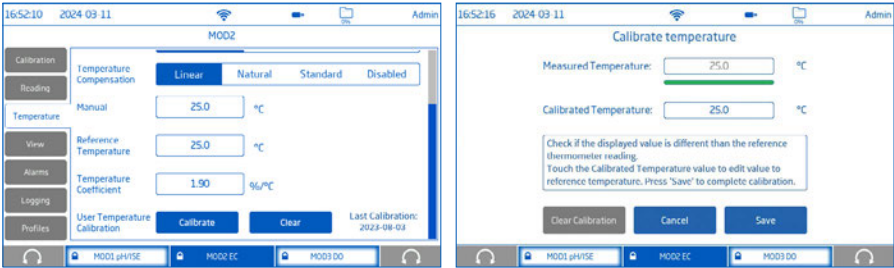

14.1.4. View

Options: **Basic**, **Simple GLP**, **Full GLP** (Conductivity, Salinity %), **Graph**, **Table**

See section [9.1. View](#) for details.

When Direct/USP reading mode is selected, meter will automatically default to Basic view.

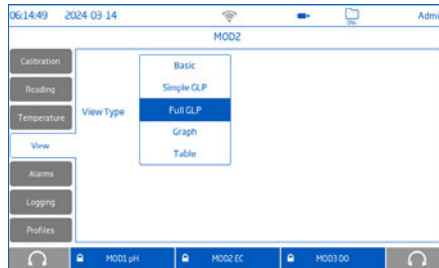

14.1.5. Alarms

Options: **High Conductivity** (Resistivity, TDS, Salinity), **Low Conductivity** (Resistivity, TDS, Salinity), **High Temperature**, **Low Temperature**

See section [9.2. Alarms](#) for details.

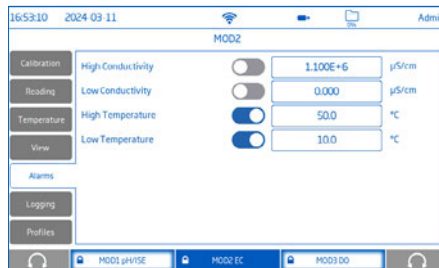

14.1.6. Logging

Options: **Automatic, Manual, Autohold**

See section [9.3. Logging](#) for details.

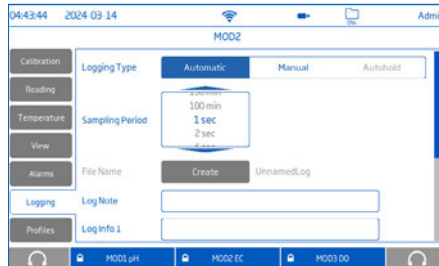

14.1.7. Profiles

See section [9.4. Profiles](#) for details.



14.2. CONDUCTIVITY CALIBRATION

HI6000 meter allows two types of conductivity calibrations:

- Conductivity calibration to calculate offset and slope (up to 4 points):
 - Offset: $0 \mu\text{S}/\text{cm}$
 - Slope: $84 \mu\text{S}/\text{cm}$, $1413 \mu\text{S}/\text{cm}$, $5000 \mu\text{S}/\text{cm}$, $12880 \mu\text{S}/\text{cm}$, $80000 \mu\text{S}/\text{cm}$, and $111800 \mu\text{S}/\text{cm}$
- Salinity calibration using 100 % salinity standard.

Note: Conductivity calibration is only available when conductivity is selected on the reading tab. Salinity calibration is only available when salinity and % is selected on the reading tab.

14.2.1. Calibration Guidelines

- Remove plastic bung prior to calibration.
- Clean the probe in distilled water, shake off water droplets, and allow to dry prior to calibration.
- Use a calibration standard with a value that is close to that of the sample.
- Inspect the probe for debris or blockages.
- Ensure the vent holes are completely submerged.
- Tap the probe to remove any air bubbles that may be trapped inside the sleeve.

- To minimize cross-contamination, when a two-point calibration is required, use two beakers: one for rinsing the probe and the other for calibration.
- For measurements across a temperature gradient (when water temperature is drastically different from the standards), allow the probe to reach thermal equilibrium before conducting calibrations or making measurements.

14.2.2. Automatic Conductivity Calibration Procedure

With the probe connected to the meter:

To calibrate the **offset**:

1. Suspend the probe in the air.
Allow for the reading to stabilize.
The standard value is automatically recognized.
2. After the reading has stabilized, tap **Confirm Standard**.
The calibration point is added to the tray.
3. Tap **Save** to update the calibration and save a single point calibration and return to the measurement screen.

To calibrate the **cell factor**:

1. Raise and lower the probe in rinse beaker of standard.
Discard rinse standard.
2. Immerse the sensor in standard.
The standard value is automatically recognized.
3. Allow reading to stabilize then tap **Confirm Standard**.
Repeat procedure for a total of four calibration points.
4. Tap **Save** to update the calibration and return to the measurement screen.



14.2.3. Manual Conductivity Calibration Procedure

To calibrate the **offset**:

1. Suspend the probe in the air. Allow for the reading to stabilize.
Tap **Edit Standard** to modify the calibration point.
2. After the reading has stabilized, tap **Confirm Standard**. The calibration point is added to the tray.
3. Tap **Save** to update the calibration and save a single point calibration and return to the measurement screen.

To calibrate the **cell factor**:

1. Raise and lower the probe in rinse beaker of standard.
Discard rinse standard.
2. Immerse the sensor in standard.
Allow for the reading to stabilize.
3. Tap **Edit Standard** to modify the calibration point.
4. After the reading has stabilized, tap **Confirm Standard**. The calibration point is added to the tray.
Repeat procedure for a total of four calibration points.
5. Tap **Save** to update the calibration and return to the measurement screen.

14.2.4. Salinity Calibration

1. Raise and lower the probe in rinse beaker of standard.
Discard rinse standard.
2. Immerse the sensor in standard.
3. After the reading has stabilized, tap **Confirm Standard**. The calibration point is added to the tray.
4. Tap **Save** to update the calibration and return to the measurement screen.

14.3. EC MEASUREMENT

When to measure conductivity instead of resistivity

Resistivity is the reciprocal of conductivity and their scales emphasize different areas of the measurement range.

Resistivity is commonly used in ultrapure water.

Conductivity is suitable for measuring larger amounts of contaminants.

Users can subsequently change parameter to Resistivity to measure in resistivity units ($M\Omega \cdot cm$).

Recommended temperature compensation setting for these type of measurements is **Standard**.

14.3.1. Measurement Tips

- Connect the probe to the meter.
- Make sure the electrode has been recently calibrated and is working correctly.
- Use the **H1764060** electrode holder for easy transfer in and out of containers during calibration and sample measurement; and for storage.
- Ensure plastic bung is removed prior to taking measurements.
- To limit sample contamination, pour two beakers of calibration standards.
Use one beaker to rinse the sensor and another one for measurement.

***Note:** Use the same size beaker and immersion depth for samples and calibration standards.*





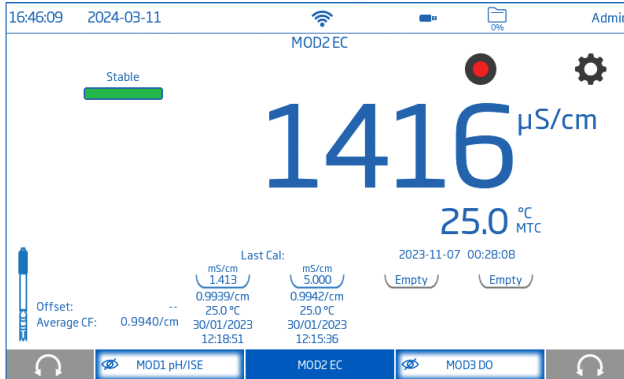

- Ensure the vent holes are completely submerged.
- Tap the probe to remove any air bubbles that may be trapped inside the sleeve.
- If measuring across a temperature gradient, allow the sensor to reach temperature equilibrium.
If using manual temperature compensation, input the sample temperature.
- Once the reading indicates "Stable", record measurement data.

14.3.2. Direct Readings

- Place the probe into the sample to be measured. Ensure the vent holes are completely submerged. Allow time for the reading to stabilize.
- Unstable status is indicated on the screen until measurement is stabilized.
- The measured value is displayed on the LCD.



14.3.3. Direct/Autohold Readings

- Place the probe into the sample to be tested. Ensure the vent holes are completely submerged.
- Tap  to enable the autohold reading mode.
- Measured value is displayed on the LCD.  is displayed blinking.
- Once the stability criteria is reached, the measured value is frozen on the display and  stops blinking.
- To release the autohold and return to direct reading mode, tap , , , or .



14.3.4. Direct/USP Readings (Conductivity Only)

The United States Pharmacopoeia Regulations establishes limits and calibration requirements for WFI (Water For Injection). This method allows the user to check for water quality using the United States Pharmacopoeia standard (USP <645>) guidelines for water for injection.

The USP standard consists of three stages, one in-line and two off-line tests.

- Go to **Reading** tab and depending on whether previously performed, toggle **Meter Verification** and **Cell Validation** functions on or off.
- Set **USP Factor** to the desired value.
- Tap **○** key to return to measurement screen.
- Tap **Start USP** to start the USP method.

Note: Previous conductivity calibration needs to be cleared before starting the USP method. If a calibration exists, the meter will prompt the user to confirm clearing the calibration.

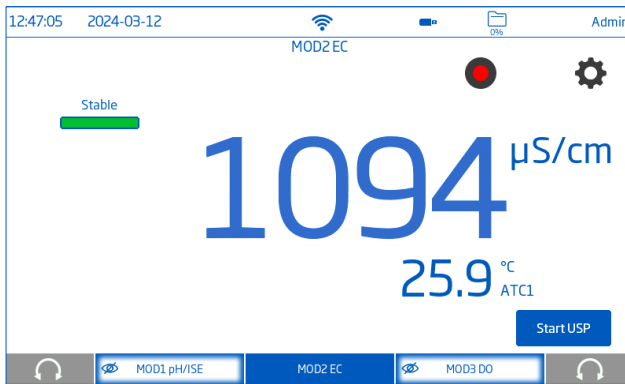

USP Meter Verification (if enabled)

- Remove the sensor connection.
- Install the meter verification plug.
- Tap **Next**.
The meter will complete the Meter Verification step.
The verification will be updated automatically when it is complete.
- Tap **Next** to start the Cell Validation (or Stage 1).

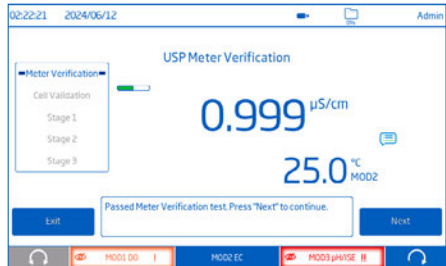

USP Cell Validation (if enabled)

- Connect the EC sensor.
- Enter the cell-constant value for the sensor used. See certification document.
- Rinse the sensor and beaker with [HI7031](#) conductivity standard.

- Place fresh **HI7031** standard into the beaker.
- Tap **Next**.
- The meter will complete the Cell Validation step.
The validation will be updated automatically when it is complete.
- Tap **Next** to start Stage 1.

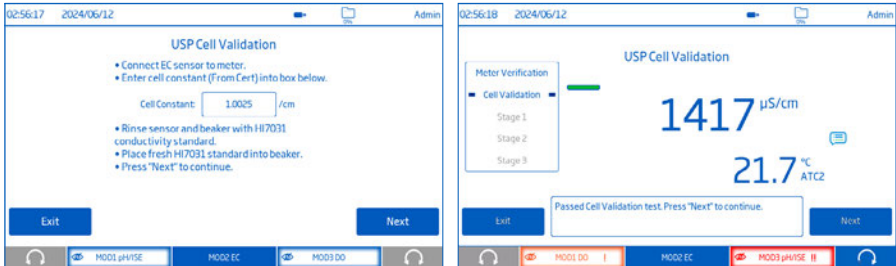

USP Bulk Water > Stage 1

When using a beaker:

- Transfer a Stage 1 suitable sample into the beaker.
- Place the pre-rinsed EC sensor into the electrode support arm.
- Immerse the sensor into the beaker, positioning it away from the walls.

When using a flow cell:

- Place the pre-rinsed EC sensor into the flow cell.
- Securely clamp the flow cell to prevent movement.
- Connect the inlet tubing to the bottom of the flow cell.
- Adjust the flow rate as needed.
- Remove any entrapped bubbles.

After completing the setup, tap **Next** to initiate Stage 1 testing.

Alternatively, tap **Exit** to leave the USP method.

During USP Stage 1 testing, tap **Next** to skip this stage and go directly to Stage 2.

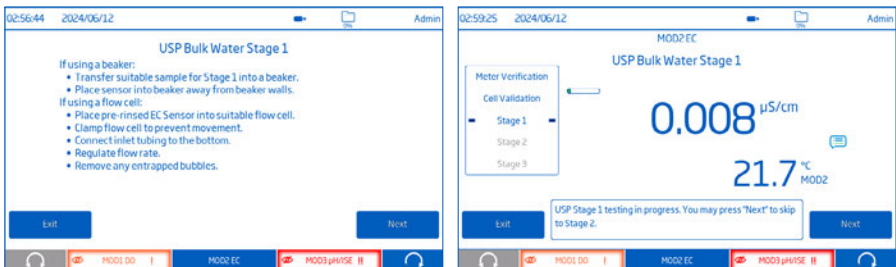

USP Bulk Water › Stage 2

- Transfer 100 mL of Stage 1 water into a clean, temperature-controlled beaker. Maintain the sample temperature at 25.0 ± 1.0 °C.
- Place the pre-rinsed EC sensor into the electrode support arm.
- Immerse the sensor into the beaker, positioning it away from the walls.
- Gently tap the sensor to remove any entrapped bubbles.
- Vigorously stir the sample to equilibrate it with the atmosphere.

After completing the setup, tap **Next** to initiate Stage 2 testing.

Alternatively, tap **Exit** to leave the USP method.

If the measured conductivity is less than $2.1 \mu\text{S}/\text{cm}$, then the sample has met the USP requirements.



If the sample has not met this requirement, tap **Next** to start Stage 3.

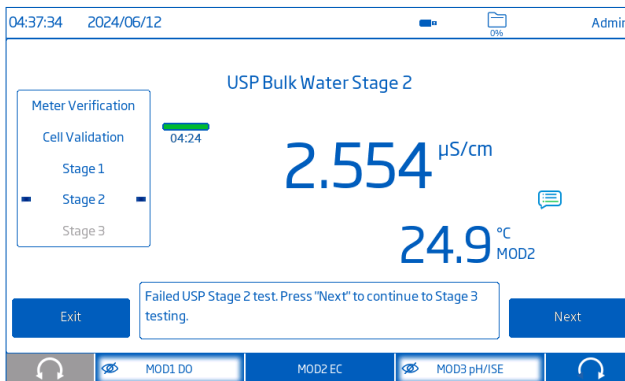

USP Bulk Water > Stage 3

If the water sample has failed Stage 1 and Stage 2 tests, Stage 3 testing must be conducted. Stage 3 requires a pH measurement be made within 5 minutes on the Stage 2 water sample.

- Remove the EC sensor from the sample.
- Retain 100 mL of the Stage 2 CO₂-equilibrated water in the temperature-controlled beaker. Maintain the sample temperature at 25.0 ± 1.0 °C
- Add 300 µl of saturated Potassium Chloride to the sample.
- Continue stirring the sample.
- Place the previously calibrated pH sensor into the electrode support arm.
- Immerse the pH and temperature sensors into the sample.

Tap **Next** to initiate the sample evaluation, or enter the determined pH value in the text box.

Tap **Next** and wait for the testing to finish.

Alternatively, tap **Exit** to leave the USP method.

04:38:32 2024/06/12 Admin

USP Bulk Water Stage 3

- Stage 3 requires a pH measurement be made within 5 minutes, on the Stage 2 water sample.
- Remove EC sensor from sample.
- Retain 100mL of the Stage 2 CO₂ equilibrated water in the temperature-controlled beaker.
- Maintain the sample temperature at 25.0°C +/- 1.0°C
- Add 300 µL of saturated Potassium Chloride to the sample
- Continue stirring the sample.
- Place the pre-calibrated pH sensor into electrode support arm.
- Place pH and temperature sensors into the sample.
- Press "Next" to initiate the sample evaluation or enter the determined pH value here, then press Next.

Exit pH Module 6.8 pH Next

MOD1 DO MOD2 EC MOD3 pH/ISE

04:39:28 2024/06/12 Admin

USP Bulk Water Stage 3

Meter Verification

Cell Validation 02:31

Stage 1

Stage 2

Stage 3

6.9 pH

25.0 °C ATC2

USP Stage 3 testing in progress.

Exit Next

MOD1 DO MOD2 EC MOD3 pH/ISE

15. DISSOLVED OXYGEN MEASUREMENTS

15.1. MEASUREMENT SETTINGS

Connect DO electrode to the connector on rear of meter.

Tap  from the measurement screen to view the measurement settings.

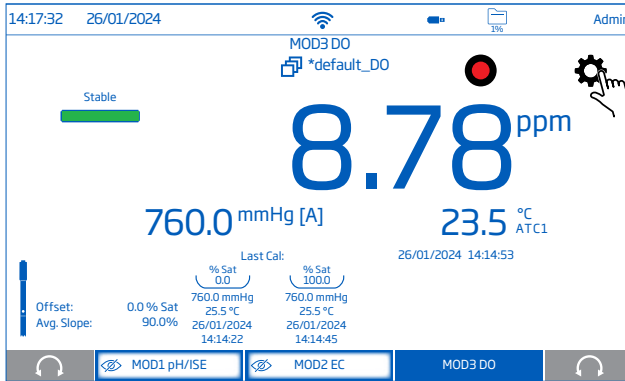

15.1.1. Calibration

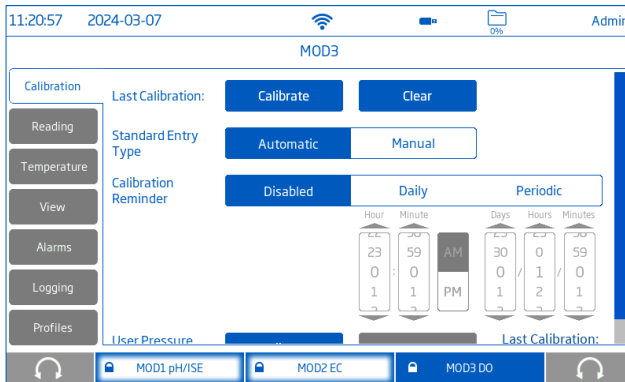

Last Calibration

Options: **Calibrate**, **Clear**

- **Calibrate**: starts a new user calibration.
- **Clear**: deletes the DO calibration for the selected hardware module.

A default calibration will replace the actual electrode calibration until a new calibration is made.

Standard Entry Type

Options: **Automatic**, **Manual**

- **Automatic**: instrument automatically selects closest standard value to the sample being measured.
- **Manual**: user can manually input the standard to be used for calibration.

Calibration Reminder

Options: **Disabled, Daily, Periodic**

- **Daily:** set the time of day the calibration reminder needs to be displayed.
- **Periodic:** schedule time in days, hours and/or minutes after the last calibration for the calibration reminder to be displayed.
“Calibrate probe” message is displayed after the calibration reminder period has elapsed.

User Pressure Calibration

Options: **Calibrate, Clear**

- **Calibrate:** starts a new user calibration.
- **Clear:** deletes the pressure calibration on the meter. The factory calibration is then used.

The screenshot shows the MOD3 user interface. At the top, it displays the time 13:05:24, date 2024-03-07, and the user name Admin. The main section is titled 'MOD3' and contains a 'Calibration' panel. On the left, there are menu options: Reading, Temperature, View, Alarms, Logging, and Profiles. The 'Calibration' panel has a 'Standard Entry Type' section with 'Automatic' and 'Manual' buttons. Below that is the 'Calibration Reminder' section, which is currently set to 'Daily'. It includes a time picker with fields for Hour (23), Minute (59), AM/PM (AM), Days (30), Hours (0), and Minutes (59). At the bottom of the panel are 'Calibrate' and 'Clear' buttons, and a status indicator 'Last Calibration: Not Calibrated'. At the very bottom, there are three device status indicators: MOD1 pH/ISE, MOD2 EC, and MOD3 DO.

To perform a new calibration:

1. Tap **Calibrate**.
2. Place a reference barometer near the meter.
Allow for the reading to stabilize.
3. If the displayed value is different than the reference barometer reading, tap **Calibrated Pressure** value.
Use the on-screen keypad to edit.
4. Tap **Save** to confirm and save the data.

The 'Calibrate pressure' dialog box shows two input fields. The 'Measured Pressure' field contains the value 747.2 mmHg. The 'Calibrated Pressure' field also contains 747.2 mmHg, and a hand icon is shown pointing to it, indicating it is being edited. Below the fields is a text box with instructions: 'Compare Measured Pressure with the reference barometer. To adjust the reading touch the Calibrated Pressure box and edit pressure value. Press "Save" to complete calibration.' At the bottom, there are three buttons: 'Clear Calibration', 'Cancel', and 'Save'.

15.1.2. Reading

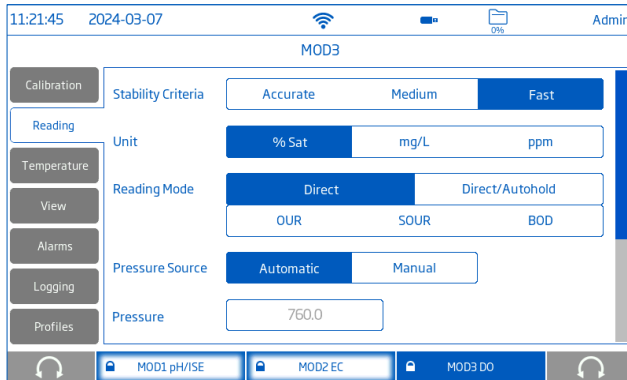

Stability Criteria

Options: **Accurate**, **Medium**, **Fast**

- **Accurate:** for applications where high accuracy is required.
Measurement is recognized as stable using more critical criteria evaluating measurement fluctuations.
- **Medium:** for applications where average accuracy is accepted.
Measurement is recognized as stable using less critical criteria evaluating measurement fluctuations.
The measurement may still change after registering stable.
- **Fast:** for applications where speed of delivery has priority.

While the measurement is changing, the stability indicator is shown partially as indicated here: 

When the criteria is reached the indicator is displayed as a full green bar as indicated here: 



Unit

Options: **% Sat** (Direct and Direct/Autohold), **mg/L**, **ppm**

Select the desired units for the measurement.

Reading Mode

Options: **Direct**, **Direct/Autohold**, **OUR**, **SOUR**, **BOD**

- **Direct:** as measurement changes, measurement stability is continuously evaluated.
"Unstable" (blinking) or "Stable" is displayed above the stability indicator.
- **Direct/Autohold:** measurements are initiated using the  icon.
When the measurement is stable, value is frozen on the display.
Tap the  icon to release the autohold reading.
- **OUR:** Oxygen Uptake Rate is the oxygen uptake rate calculated during a certain time period; and is reported as milligrams of oxygen consumed per hour.
- **SOUR:** Specific Oxygen Uptake Rate is the oxygen consumption rate per unit time per unit mass of total solids; and it is reported as milligram of oxygen consumed per gram of solids per hour.
- **BOD:** Biological Oxygen Demand is measured by incubating a sample of water for five days and measuring the dissolved oxygen concentration before and after.

Pressure Source

Options: **Automatic, Manual**

- **Automatic:** Pressure is measured automatically using the meter's integrated barometer.
- **Manual:** Pressure is manually entered by the user.

DO readings (concentration and %) vary with pressure.

Pressure

Options: **vary** based on pressure unit

To manually input the pressure value:

1. Select pressure unit.
2. Tap the **Pressure** input field.
3. Enter pressure value.
4. Tap  to confirm.

Pressure Unit

Options: **mmHg, mbar, kPa, inHg, psi, atm**

Select the desired units for the pressure measurement.

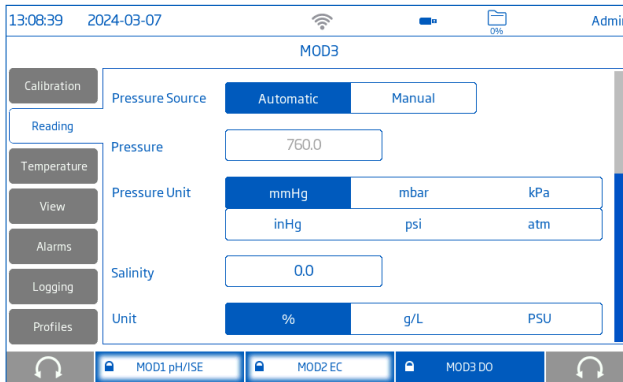

The screenshot shows the MOD3 calibration interface. At the top, the time is 13:08:39 and the date is 2024-03-07. The screen is titled 'MOD3' and has an 'Admin' user indicator. On the left, there is a vertical menu with options: Calibration, Reading, Temperature, View, Alarms, Logging, and Profiles. The main area is divided into sections for different parameters:

- Pressure Source:** A toggle switch between 'Automatic' (selected) and 'Manual'.
- Pressure:** A text input field containing the value '760.0'.
- Pressure Unit:** A grid of buttons for selecting units: mmHg (selected), mbar, kPa, inHg, psi, and atm.
- Salinity:** A text input field containing the value '0.0'.
- Unit:** A toggle switch between '%' (selected), 'g/L', and 'PSU'.

At the bottom, there are three tabs for other modules: 'MOD1 pH/ISE', 'MOD2 EC', and 'MOD3 DO' (which is active). Navigation arrows are visible at the bottom corners.

Salinity

Options: **0.0 to 130.0 Sal (%)**, **0.00 to 45.00 Sal (g/L, PSU)**

Concentration measurements (ppm and mg/L) in seawater samples require the salinity-value input to account for the lower solubility of oxygen in saltwater.

To manually input the salinity value:

1. Select salinity unit.
2. Tap the Salinity input field.
3. Enter Salinity value.
4. Tap  to confirm.

Salinity Unit

Options: **%, g/L, PSU**

Select the desired units for the salinity measurement.

15.1.3. Temperature

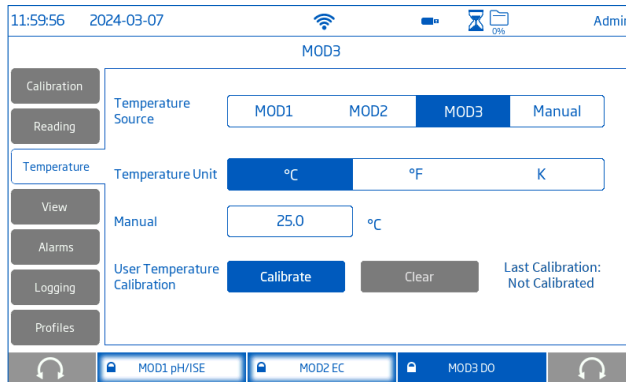

Temperature Source

Options: **Automatic (MOD1, MOD2, MOD3), Manual**

Users can select between physical temperature input source (MOD1, MOD2, MOD3) or entering sample temperature value manually.

- **Automatic:** built-in temperature sensor adjusts measured dissolved oxygen.
ATC indicates temperature compensation status.
- **Manual:** sample temperature is entered manually.
MTC indicates temperature compensation status.

Temperature Unit

Options: °C, °F, K

Users can select the temperature unit.

Manual

Options: **-20.0 to 120 °C (-4.0 to 248.0 °F, 253.2 to 393.2 K)**

To manually input the temperature value:

1. Select the temperature unit.
2. Tap the Manual input field.
3. Enter temperature value.
4. Tap  to confirm.

User Temperature Calibration

Options: **Calibrate, Clear**

- **Calibrate:** starts a new user calibration.
- **Clear:** deletes the temperature calibration for the attached probe and channel.

To perform a new calibration:

1. Tap **Calibrate**.
2. Place the probe and a reference thermometer with 0.1 resolution into a stirred container of water.
Allow for the reading to stabilize.

- If the displayed value is different than the reference thermometer reading, tap Calibrated Temperature field and use the on-screen keypad to enter the value.
- Tap **Save** to confirm and save the data.

Calibrate temperature

Measured Temperature: °C

Calibrated Temperature: °C

Check if the displayed value is different than the reference thermometer reading.
Touch the Calibrated Temperature value to edit value to reference temperature. Press 'Save' to complete calibration.

Clear Calibration
Cancel
Save

15.1.4. View

Options: **Basic, Simple GLP, Full GLP, Graph, Table**

See section [9.1. View](#) for details.

When SOUR, OUR, BOD is selected, meter will automatically default to Basic view.

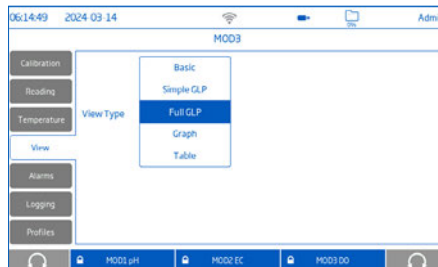

15.1.5. Alarms

Options: **High DO, Low DO, High Pressure, Low Pressure, High Temperature, Low Temperature**

See section [9.2. Alarms](#) for details.

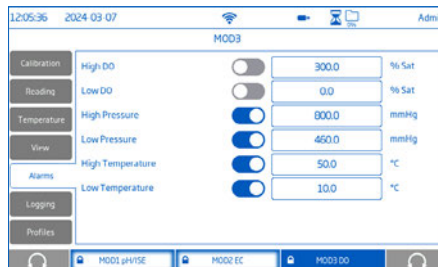

15.1.6. Logging

Options: **Automatic, Manual, Autohold** (Direct and Direct/Autohold only)

See section [9.3. Logging](#) for details.

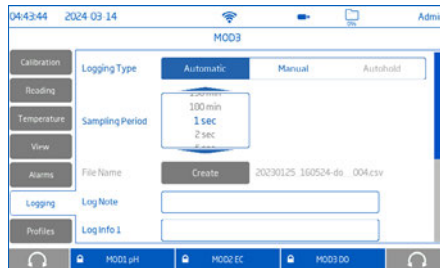

15.1.7. Profiles

See section [9.4. Profiles](#) for details.



15.2. DISSOLVED OXYGEN CALIBRATION

The accuracy of dissolved oxygen measurements is directly related to the sensing-surface cleanliness and calibration technique. Oily coatings and biological contaminations are the primary cause of calibration drift. A standard solution or a reference DO meter may be used to compare readings during calibration.

HI6000 system supports:

- **Two-point calibration** at 100.0 % saturation (8.26 mg/L) and 0.0 % saturation (0.00 mg/L)
- **Single-point calibration** at 100.0 % saturation (8.26 mg/L), 0.0 % saturation (0.00 mg/L), or a value set by the user (% saturation or mg/L).

15.2.1. Calibration Guidelines

- Set up a routine service schedule where measurement integrity is validated.
- Do not handle the sensing surface of the sensor.
- Avoid rough handling and abrasive environments that can scratch the reactive surface of the sensor.
- Do not return the used standard to the bottle of “fresh” solution.
- For measurements across a temperature gradient (when water temperature is drastically different from the standard), allow the sensor to reach thermal equilibrium before conducting calibrations or making measurements. The heat capacity of the probe is much greater than the air.
- During calibration, the temperature sensor must be in the calibration solution.

- When calibrating in water-saturated air ensure there are no droplets on the DO sensor sensing surface.
- Perform Temperature and/or Pressure calibration (if required) prior to DO probe calibration.
- If calibrating in concentration units, 8.26 mg/L (ppm) is displayed but the actual value of air-saturated water at pressure and temperature used for calibration.
- When automatic calibration is performed it is assumed that the standard value is 100 % water-saturated air and 0 % O₂ saturated solution.
- When a user calibration is performed it is assumed that the standard value is the DO value at the current pressure, temperature, and salinity.

15.2.2. Automatic DO Calibration

With the probe connected to the meter:

Calibrate at 100 % saturation (8.26 mg/L)

- Optical probe
 - Place a moistened sponge in the bottom of the calibration beaker.
 - Place the calibration beaker on the probe body. Do not tighten the calibration beaker on the probe threads.
 - Wait at least 15 minutes for the air to become saturated with water vapor.
This condition corresponds to 100 % air-saturated water at the temperature of measurement.
- Polarographic probe
 - Suspend probe with membrane just over beaker of water. Do not put the sensor in an sealed container.
 - Wait for “Stable” to appear before confirming the standard.
- Allow for the reading to stabilize. The standard value is automatically recognized.
- After the reading has stabilized, tap **Confirm Standard**. The calibration point is added to the tray.
- Tap **Save** to update the calibration and save a single point calibration; and return to the measurement screen.

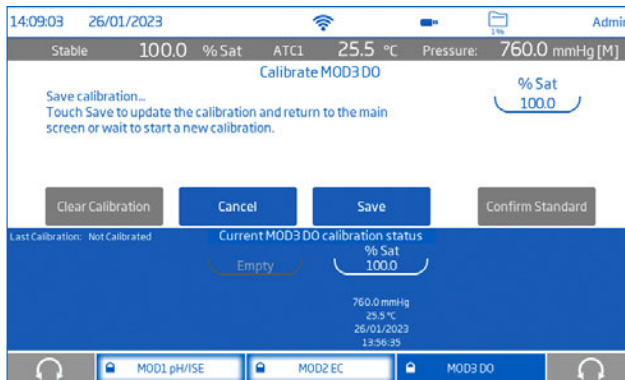

Calibrate at 0 % saturation (0 mg/L)

- Fill the calibration beaker 2/3 full with HI7040 Zero Oxygen solution and slowly place the probe in the solution.
- Dislodge bubbles that may adhere to the sensor.
- Stir gently for 2-3 minutes.

- Wait for “Stable” to appear before confirming the standard.
After the reading has stabilized, tap **Confirm Standard**. The calibration point is added to the tray.
- Tap **Save** to update the calibration and return to the measurement screen.



15.2.3. Manual DO Calibration

1. Raise and lower the probe in rinse beaker of standard. Discard rinse standard.
2. Immerse the sensor in standard.
3. Tap **Edit Standard** to modify the calibration point.
The concentration of the standard needs to be determined independently.
4. After the reading has stabilized, tap **Confirm Standard**. The calibration point is added to the tray.
5. Tap **Save** to update the calibration and return to the measurement screen.

15.3. DISSOLVED OXYGEN MEASUREMENT

15.3.1. Measurement Tips

- Verify the temperature sensor is submerged in sample during measurement.
- Allow the probe to reach thermal equilibrium with the sample.
- Verify if pressure and temperature measurements are reading correctly.
- Verify the probe is calibrated in accordance with sampling protocols.
- The probe should be measuring the partial pressure of the dissolved oxygen in water.
Gas bubbles have a greater partial pressure due to the surface tension of the bubble. Noisy (erratic) measurement or even higher measurements are possible.
- Set Salinity value if measuring ocean or brackish water samples.
- Carefully lower the probe into sample so no trapped air bubbles at the cap.
- Routinely inspect the probe for biofouling.
- Routinely clean off the probe with clean water (between measurements). Biologically active waters may require more frequent cleaning.
- For good sample circulation make sure the optical window/membrane is clean, without any coating.
- Only work with recently calibrated probes.

- Use the [HI764060](#) holder for easy transfer in and out of containers during sample measurement.
- To limit sample contamination, pour 2 beakers of sample.
Use one beaker to rinse the sensor, and another one for measurement.
- Once the reading indicates **Stable**, record measurement data.
- When using the polarographic probe, to ensure accuracy, the membrane needs constant oxygen replenishment.
Ensure adequate water movement either manually or by use of a stirrer.



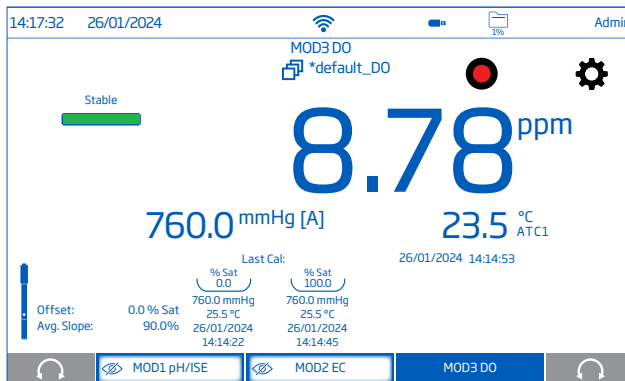

Note: For DO readings (ppm or mg/L), salinity values set to a value higher than 0 are displayed alternating with pressure values.

15.3.2. Direct Readings

- Place the probe into the sample to be measured.
Allow time for the reading to stabilize.
“Unstable” status is indicated on the screen until measurement is stabilized.
- The measured value is displayed on the LCD.



15.3.3. Direct /Autohold Readings

- Place the probe into the sample to be tested.
- Tap  to enable the autohold reading mode.
- The measured parameter value will be displayed on the LCD.
 is displayed blinking.
- Once the stability criteria is reached, the measured value is frozen on the display.
 stops blinking.
- Tap  to release the autohold and return to direct reading mode.

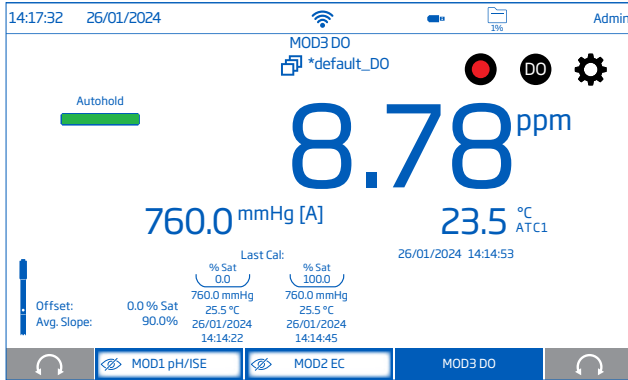

15.3.4. Oxygen Uptake Rate (OUR)

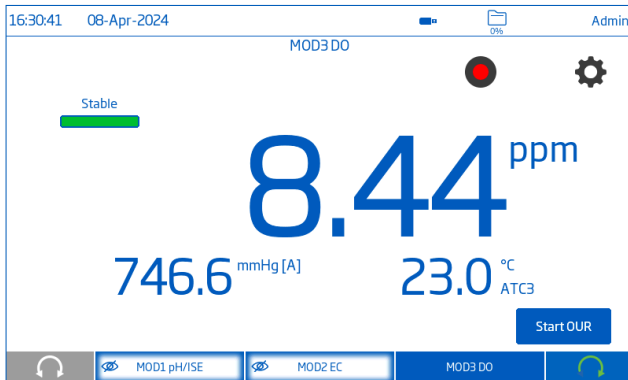

See section [15.1.2. Reading](#) for SOUR setup parameters.

- Tap **Start OUR** to start the oxygen uptake rate method.

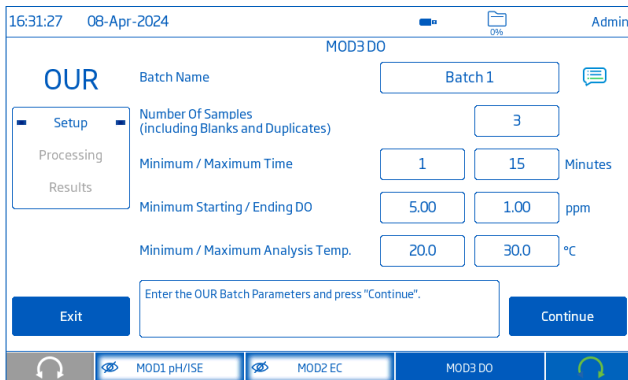

- Edit the batch parameters then tap **Continue** to enter the sample information.



- Tap  to enter a sample name and select the sample type.
- Tap  to modify batch parameters.
- Tap **Verify Calibration** to check calibration.
- Place the calibrated probe into the sample then tap **Start**.

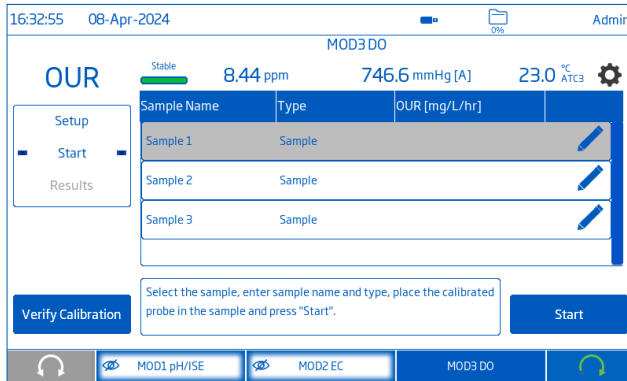

- The screen shows the current reading value, a graph representing readings over the set time interval, and the remaining time.
- Tap **Sample Table (Graph)** to toggle between table and graph.
- Tap **Save** to save the current method data and to return to measurement screen.

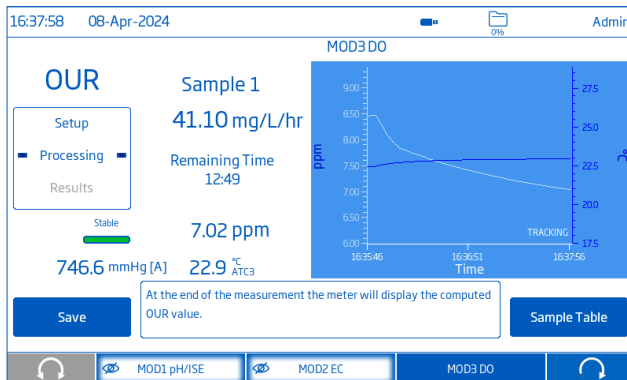

- At the end of the measurement the meter will display the OUR value as mg/L/hr.

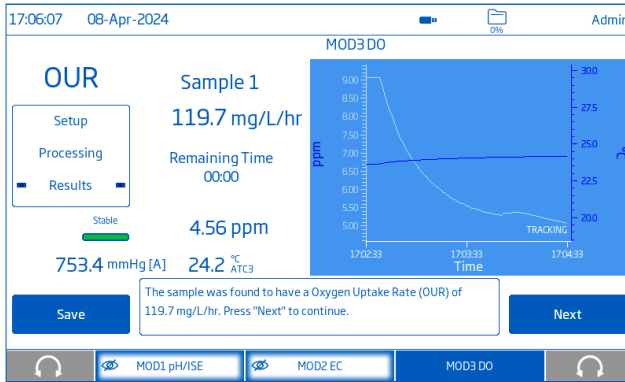

- Place the calibrated probe into the sample.
- Tap **Next** to proceed with the next sample.
- Once the analysis has finished, the results are displayed in the table.



- Tap **Save** to save the log report and return to the measurement screen.

The screenshot shows the 'Reports' screen. At the top, it displays the time 17:15:58 and date 08-Apr-2024. The screen has a header with 'View', 'Select All', 'Deselect All', 'Reports', 'Delete', and 'Share' buttons. Below is a table with the following data:

Name	Report Type	Module	Start/Stop	Result
20240408_170232-do_OUR_Batch_1_3.csv	DO-OUR	MOD3 DO	17:02:32 08-Apr-2024 17:11:30 08-Apr-2024	3
20240408_170036-do_OUR_Batch_1_3.csv	DO-OUR	MOD3 DO	17:00:36 08-Apr-2024 17:01:49 08-Apr-2024	1
20240408_163530-do_OUR_Batch_1_3.csv	DO-OUR	MOD3 DO	16:35:30 08-Apr-2024 16:35:34 08-Apr-2024	1

15.3.5. Specific Oxygen Uptake Rate (SOUR)

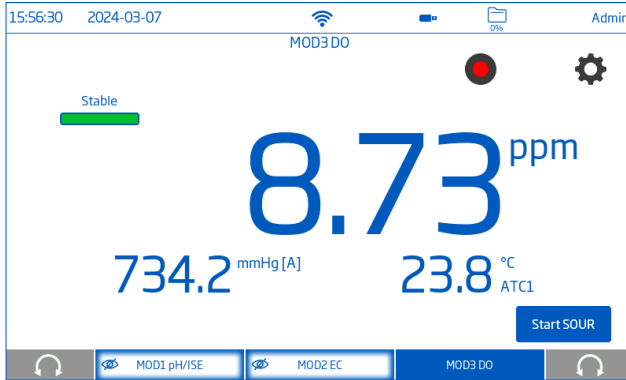

See section [15.1.2. Reading](#) for OUR setup parameters.

- Tap **Start SOUR** to start the specific oxygen uptake rate method.

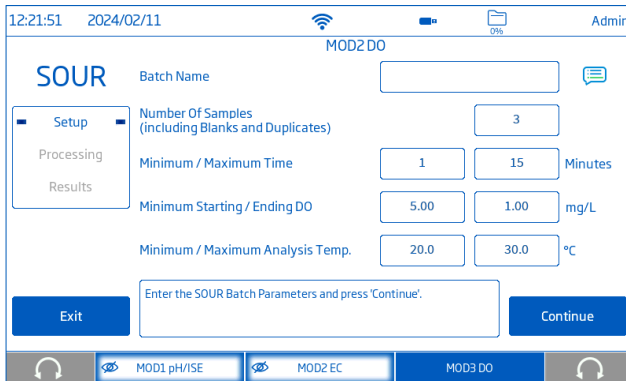

- Edit the batch parameters then tap **Continue** to enter the sample information.



- Tap  to enter a sample name, select the sample type, and enter the solid weight.
- Tap  to modify batch parameters.
- Tap **Verify Calibration** to check calibration.

- Place the calibrated probe into the sample then press **Start**.

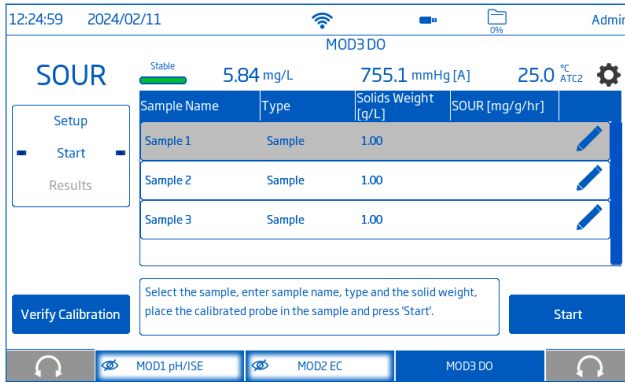

- Verify probe calibration.
- Tap **Continue** to return to the analysis.
- At the end of the measurement the computed SOUR value is displayed.
- The screen shows the current reading value, a graph representing readings over the set time interval, and the remaining time.
- Tap **Sample Table (Graph)** to toggle between table and graph.

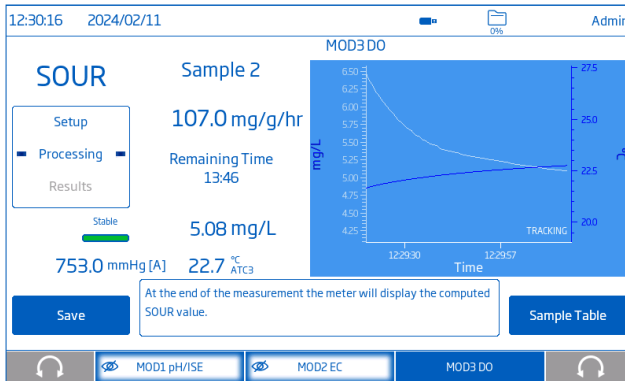

- Tap **Save** to save the current method data and return to measurement screen.

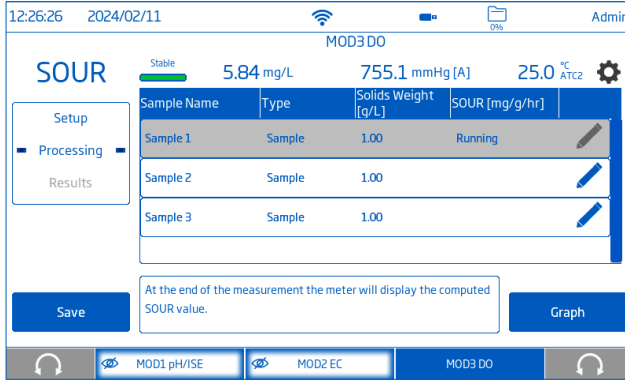

- At the end of the measurement the meter will display the SOUR value as **mg/g/hr**.
- Tap **Next** to proceed with the next sample.
- Once the analysis has finished, the results are displayed in the table.
- Tap **Save** to save the log report and return to the measurement screen.

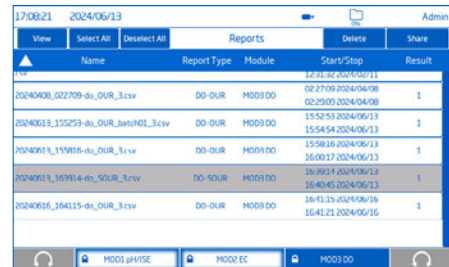
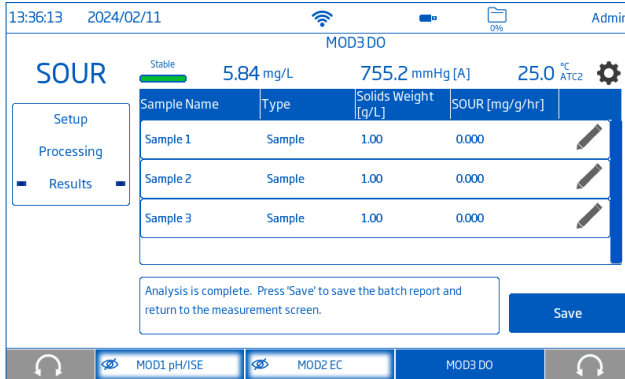

15.3.6. Biological Oxygen Demand (BOD)

The HI6000 containing the HI6000-4 (DO) module has a BOD mode for batch analysis of BOD samples without the need of additional computer software.

BOD (Biochemical Oxygen Demand) is an empirical test used to determine the relative oxygen requirements of wastewaters, effluents, and polluted waters. The test is used to determine the oxygen required for the biochemical degradation of organic material (carbonaceous demand) and the oxygen used to oxidize inorganic material such as sulfides and ferrous ions. It may also measure the oxygen used to oxidize reduced forms of nitrogen (nitrogenous demand) unless their oxidation is prevented by an inhibitor.

Equipment and materials necessary for BOD analysis

- Dilution water
- Seed material
- Standards
- Clean BOD bottles (with stirrers)
- Pipets
- Graduated cylinders
- Stir plate
- BOD incubator with thermometer

Note: Follow SOP provided by authority.

Procedure guidelines

- Fill a numbered bottle with sample, dilution water, and seeding material.
- Measure dissolved oxygen using the calibrated HI764833 polarographic DO sensor.
- Incubate the bottle at 20 °C (± 1 °C) for five days (± 6 hours).
- Measure the bottles for DO content after incubation.
The BOD is computed from oxygen depletion (difference between the initial and final dissolved oxygen).
- Run along additional bottles [e.g. blanks, seeds (with varied dilution ratios), control samples (Standards)] with the samples for quality control purposes.

The meter efficiently guides the user through the procedures adhering to Standard methods guidelines and is designed to simplify measurement and calculations.

- Completed reports are saved for analysis records.
- Anomalies from SOPs or Standard Method protocols are flagged in the reported data.
- No additional PC applications or software programs are required to get completed reports of BOD analysis.
- Bottle ID can be entered manually (keyboard), bar code reader (barcoded bottles), or use Auto increment feature.
- Meter measures and saves the dissolved oxygen reading in the BOD bottle along with sample information. After incubation the bottles are again measured for Dissolved oxygen.
- Meter automatically calculates BODs/CBODs.
Duplicate samples are averaged.

- User quality-controls measures including seed corrections, dilutions, and blanks are analyzed and applied to data.
- Completed batch reports may be viewed on meter and/or downloaded as .CSV.
Reports have signature lines for Analyst and Supervisor.
- Configure User profile as BOD when multiple users are using the BOD application for the same batch.
Use this field to identify analysts and facility.
This information will be included in BOD reports.

09:26:52 2024/06/09 BOD

User Settings

User Name: BOD

Password: [Redacted]

Icon Color: [Green]

Full Name: [Redacted]

Info 1: WWTP

Info 2: 255 West Street

MOD1 pH/ISE MOD2 EC MOD3 DO

- Calibrate DO probe before starting measurements.
Calibrations can be made frequently and each calibration will be reported.

13:04:01 2024/06/14 BOD

Stable 8.14 mg/L ATC3 24.7 °C Pressure: 751.1 mmHg [A]

Calibrate MOD3 DO

Confirm standard...
Touch "Confirm" to accept calibration and continue with the next standard.

mg/L 8.26

Clear Calibration Cancel Save Confirm Standard

Last Calibration:	Current MOD3 DO calibration status	
09:12:05 2024/06/09	% Sat	% Sat
Offset: 0.0 % Sat	0.0	100.0
Slope: 100.1 %	749.4 mmHg	749.4 mmHg
	24.7 °C	24.7 °C
	2024/06/09	2024/06/09
	09:10:54	09:12:02

MOD1 pH/ISE MOD2 EC MOD3 DO

- Select BOD Reading Mode from Reading tab.

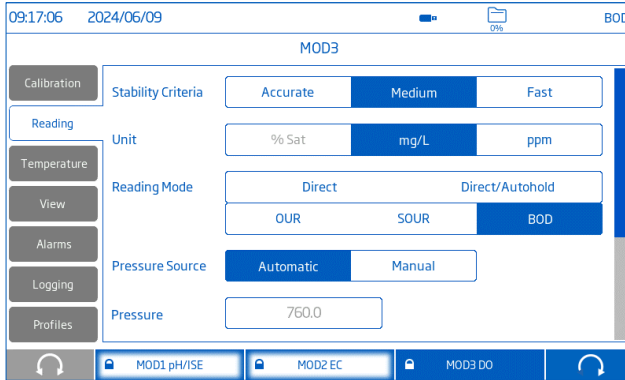

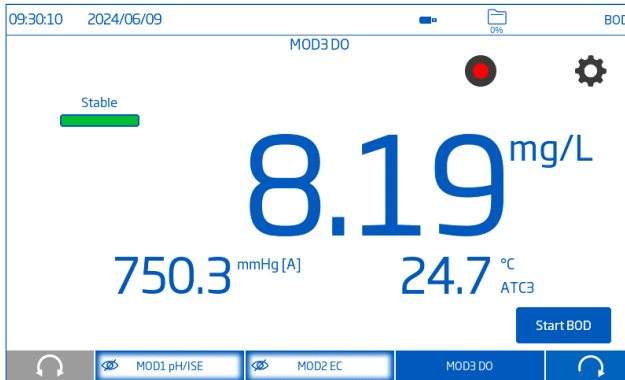

New BOD Batch

- Tap **Start BOD** to start the biological oxygen demand method.

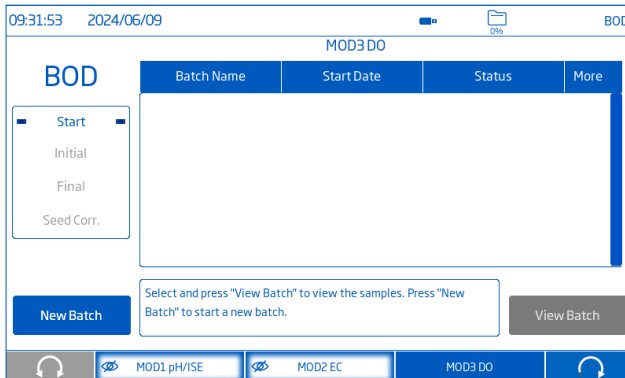

- Tap **New Batch** to start a new batch of samples.





- Provide Batch name.
Default values reflect Standard Method methodology.
- Tap the box to alter parameter.
A pop-up box appears that permits quantities to be changed.
- Tap **Save**.
- Tap  to enter additional batch information.
Consider this as notes field. Add information that applies to the entire batch.
- Tap **Save**.
- When Batch parameter changes are complete, tap **Continue**.

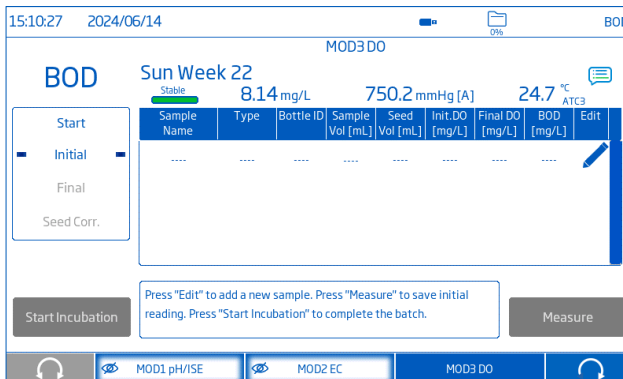

Set up and initial DO measurements

- Tap  to add a bottle to the batch.
A pop up permits the user to select a sample type.
- Select from Blank, Standard, Seed, Sample, or Duplicate.
- Tap **Confirm** to open the sheet to enter sample information.
Available fields are sample-type specific.
A sample name may be added (optional).



Sample Name	Type	Bottle ID	Sample Vol [mL]	Seed Vol [mL]	Init. DO [mg/L]	Final DO [mg/L]	BOD [mg/L]	Edit
.....	

Blank

15:25:41 2024/06/14 MOD3 DO BOD

BOD Sample Name

Type **Blank**

Sample Volume mL

Seed Volume mL

Duplicate Of Bottle ID

Predilution Factor

Bottle ID 001

None **Increment** Manual

ID Prefix

0	0	0
1	1	2

Start

Initial

Final

Seed Corr.

Edit the Sample Parameters and press "Continue" to measure the sample.

Continue

MOD1 pH/ISE MOD2 EC MOD3 DO

Standard

15:26:53 2024/06/14 MOD3 DO BOD

BOD Sample Name

Type **Standard**

Sample Volume 5.00 mL

Seed Volume 3.00 mL

Duplicate Of Bottle ID

Predilution Factor 1.00

Bottle ID 001

None **Increment** Manual

ID Prefix

0	0	0
1	1	2

Start

Initial

Final

Seed Corr.

Edit the Sample Parameters and press "Continue" to measure the sample.

Continue

MOD1 pH/ISE MOD2 EC MOD3 DO

Seed

15:28:35 2024/06/14 MOD3 DO BOD

BOD Sample Name

Type **Seed**

Sample Volume 10.00 mL

Seed Volume mL

Duplicate Of Bottle ID

Predilution Factor

Bottle ID 001

None **Increment** Manual

ID Prefix

0	0	0
1	1	2

Start

Initial

Final

Seed Corr.

Edit the Sample Parameters and press "Continue" to measure the sample.

Continue

MOD1 pH/ISE MOD2 EC MOD3 DO

Sample

15:29:42 2024/06/14 MOD3 DO BOD

BOD

Sample Name: effluent

Type: Sample

Sample Volume: 150.00 mL

Seed Volume: 3.00 mL

Duplicate Of Bottle ID: ----

Predilution Factor: 1.00

Bottle ID: 001

ID Prefix: 0 0 1 / 1 1 3

None Increment Manual

Edit the Sample Parameters and press "Continue" to measure the sample.

Continue

MOD1 pH/ISE MOD2 EC MOD3 DO

Duplicate Of Bottle ID, copies all settings from the previous bottle measured.

15:31:22 2024/06/14 MOD3 DO BOD

BOD

Sample Name: effluent

Type: Duplicate

Sample Volume: 10.00 mL

Seed Volume: 3.00 mL

Duplicate Of Bottle ID: [Empty]

Predilution Factor: 1.00

Bottle ID: 001

ID Prefix: 0 0 1 / 1 1 3

None Increment Manual

Edit the Sample Parameters and press "Continue" to measure the sample.

Continue

MOD1 pH/ISE MOD2 EC MOD3 DO

Sample Predilution

Very potent waste samples will require predilutions prior to adding to the BOD bottle.

If the sample volume would be less than 1.0 mL, a predilution is required.

The predilution factor is the ratio of the sample used to the volume of the dilution container. For example, if 20 mL potent sample is diluted to 100 mL, the predilution factor is 0.2.

Bottle ID

There are 3 ways to enter bottle ID.

1. Select **Increment** and the field will automatically increment by one.
 - If first bottle in the rack is 025, use the scroll wheel to enter the number 025.
 - The next bottle will be automatically numbered 026. A prefix (numeric or letters) may also be input.

The screenshot shows the BOD measurement interface. At the top, the time is 14:30:23 and the date is 2024/06/18. The mode is MOD3 DO. The main screen is titled 'BOD' and has a 'Sample Name' field. Below this, there are three columns of controls: 'Type' with a 'Blank' button, 'Sample Volume' and 'Seed Volume' fields (both with '----' and 'mL' units), and 'Duplicate Of Bottle ID' and 'Pretitration Factor' fields (both with '----'). To the right, there is a 'Bottle ID' field containing '025' and three buttons: 'None', 'Increment' (highlighted in blue), and 'Manual'. Below these is an 'ID Prefix' grid with a 2x3 grid of buttons: 0, 1, 2, 3, 4, 5, 6. At the bottom, there is a text box that says 'Edit the Sample Parameters and press "Continue" to measure the sample.' and a 'Continue' button. The bottom navigation bar shows 'MOD1 pH/ISE', 'MOD2 EC', and 'MOD3 DO'.

2. Barcode scanner. Barcoded BOD bottles required.
 - Connect barcode scanner to USB. Select **None** or **Manual** option.
 - Tap on Bottle ID and a keyboard opens.
 - If barcode on the bottle is being scanned, bottle number will be entered without typing it.
 - Tap **Continue** to Measure sample.
3. Manual Entry. Select **Manual**.
 - Tap on Bottle ID and a keyboard opens.
 - Use the keyboard to enter the bottle ID.
 - Tap **Continue** to Measure sample.
 - Upon tapping **Continue**, the screen will return to the table of samples.
 - Tap the sample line (gray).

The procedure typically follows these steps:

1. Add a clean stir bar to the BOD bottle with sample, blank or standard, and dilution water.
2. Transfer the cleaned DO probe to the sample BOD bottle and start the stirrer.
Once stirring has begun, allow the DO value to stabilize.
3. When the meter indicates Stable, tap **Measure**.
The initial value is added to the table.
4. Rinse the probe between different samples with DI water.

The analyst should get into a rhythm of:

rinse probe » transfer probe to next sample » stir » measure » fill BOD bottle » seal

Work through the entire batch in this fashion and finish with the final dilution water blank.

Continuing to the next sample, the batch table will fill with sample data and be displayed with the other initial sample measurements.

The entire batch table may be set up ahead of time (all measurements made in sequence) or one sample at a time.

Note: All information entered is automatically saved. Should there be a power interruption, bottle numbers, entries, and other information are saved. Tap **Start BOD** and open batch record to continue.

Batch table with Initial measurements

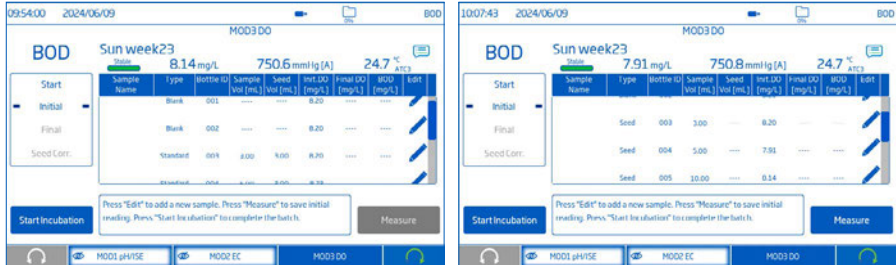

Changing sample information

- Select the sample and tap **Edit** to change sample parameters.
- After all samples have been added and initial readings saved, tap **Start Incubation** to start timing the incubation period. Once incubation begins, additional samples or adjustments to initial DO parameters or readings are not possible.
- Tap **OK** to confirm and start the incubation period.

Existing BOD Batches

- Tap **Start BOD** to open the biological oxygen demand method and view BOD data.
- All BOD batches will be displayed with status information.
- If the incubation period for the batch has not been started, tap  to modify the batch parameters or view batch.

Note: Additional samples may be added and initial DO measurements can still be modified.

- If the incubation period has been started, remaining incubation time is displayed in the Status column.
- Batches completed will say COMPLETE.
- If the incubation window has expired, the status will be in red. The final BOD may still be measured but will be marked with incubation time exceptions.
- When the incubation period has elapsed, the status column will show the time remaining in green (incubation period ± 6 hours).

- Tap  to view the batch and conduct the final DO reading within the ± 6 hour window.

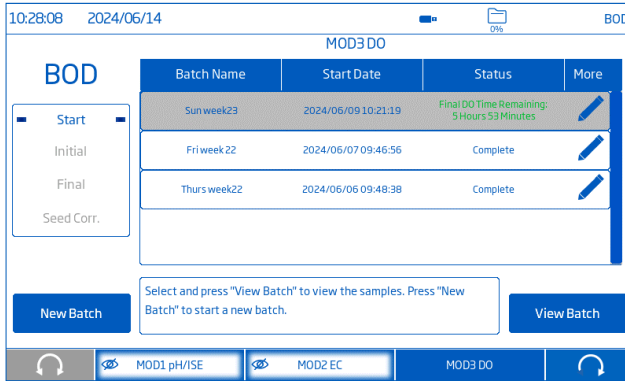

Final BOD Measurements in Selected Batch

- Remove the batch of samples from the incubator.
- Select the batch that is ready for the final BOD measurement.
- Next, select **View Batch**.
- The screen will open to the table of samples. Verify the order of bottles in the rack matches the table.

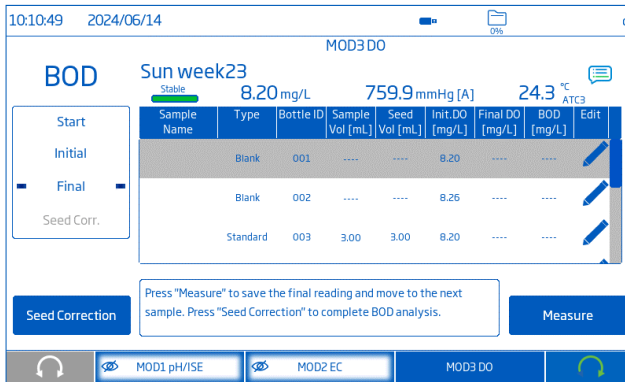

- Tap the sample line (gray) of the first sample in the batch.
- Remove the associated bottle from the rack and remove the outer caps and stoppers from one sample.

The procedure typically follows these steps:

1. Transfer the cleaned and calibrated DO probe to the sample and place on the stirrer.
2. Initiate stirring.
3. Allow the DO value to stabilize.
4. When the meter indicates Stable, tap **Measure**.

5. The final BOD is placed in the table, BOD is calculated, and it automatically moves to next sample in the table.

The screenshots show the BOD measurement interface for MOD3 DO. The left screenshot shows the 'Initial' measurement for sample 001 with a DO of 8.20 mg/L. The right screenshot shows the 'Final' measurement for sample 001 with a DO of 8.20 mg/L, and the calculated BOD of 759.9 mg/L is displayed at the top.

The analyst should get into a rhythm of:

rinse probe » transfer probe to next sample » stir » measure » repeat

Work through the entire batch in this fashion and finish with the final dilution water blank.

Rinse the probe between samples with DI water.

Any sample can be measured again if desired.

- Tap the sample line.
- Tap **Measure**.

The analyst must confirm the previous measurement will be overwritten.

Selecting seed samples for Seed Correction

- When the entire batch has been measured, select **Seed Correction**.
The Seed Correction table shows the calculated seed uptake in mg/L.
- Toggle acceptable seeds following SOP guidance.
Selected seeds will be averaged and used for seed-corrected BOD values.

The screenshot shows the BOD Seed Correction interface for MOD3 DO. It displays a table with the following data:

Sample Name	Bottle ID	Sample Vol (mL)	Init. DO (mg/L)	Final DO (mg/L)	Uptake (mg/L)	Selected
003	3.00	8.20	6.53	0.557	<input checked="" type="checkbox"/>	
004	5.00	7.91	4.34	0.714	<input checked="" type="checkbox"/>	
005	10.00	8.14	1.34	0.680	<input checked="" type="checkbox"/>	

Below the table, there is a prompt: "Select the seeds to be used for seed correction averaging and press 'Confirm'." and a "Confirm" button.

- Select the seeds to be used for seed correction averaging.

- Tap **Confirm** to view the results with seed corrections.
- An * indicates seed corrections have been applied.

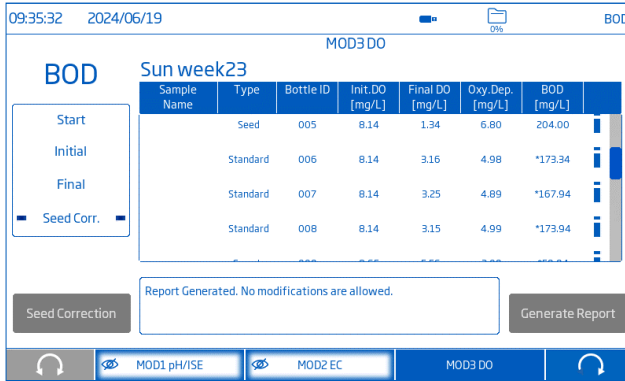

- Tap **Generate Report** to generate the .csv BOD batch report and return to the BOD batch screen.

Completed BOD Batch Reports

- To view BOD Reports, select **Reports** from the System menu screen.

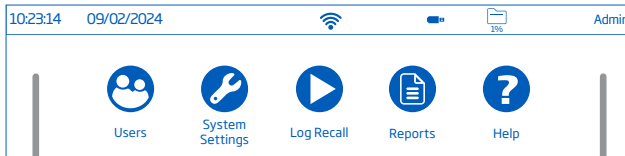

- All available BOD batches will be displayed. Tap on report (turns gray).

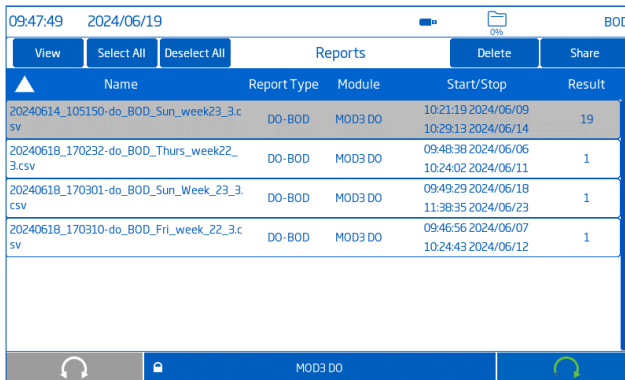

- Tap **View** to view the method parameters and data table.

- Tap **Status** to view details regarding the sample.

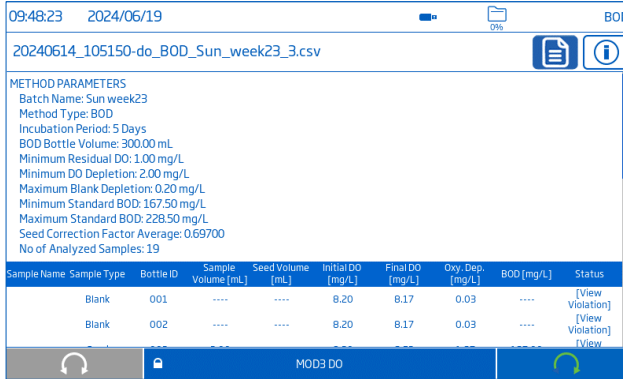

09:48:23 2024/06/19 0% BOD

20240614_105150-do_BOD_Sun_week23_3.csv

METHOD PARAMETERS
 Batch Name: Sun week23
 Method Type: BOD
 Incubation Period: 5 Days
 BOD Bottle Volume: 300.00 mL
 Minimum Residual DO: 1.00 mg/L
 Minimum DO Depletion: 2.00 mg/L
 Maximum Blank Depletion: 0.20 mg/L
 Minimum Standard BOD: 167.50 mg/L
 Maximum Standard BOD: 228.50 mg/L
 Seed Correction Factor Average: 0.69700
 No of Analyzed Samples: 19

Sample Name	Sample Type	Bottle ID	Sample Volume [mL]	Seed Volume [mL]	Initial DO [mg/L]	Final DO [mg/L]	Oxy. Dep. [mg/L]	BOD [mg/L]	Status
Blank		001	----	----	8.20	8.17	0.03	----	[View Violation]
Blank		002	----	----	8.20	8.17	0.03	----	[View Violation]

MOD3 DO

- Tap **i** to view the batch information.

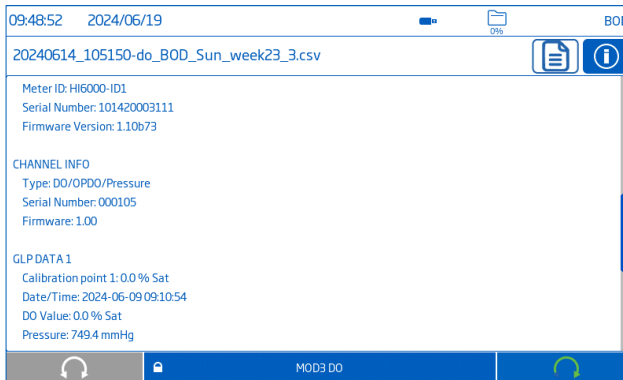

09:48:52 2024/06/19 0% BOD

20240614_105150-do_BOD_Sun_week23_3.csv

Meter ID: HI6000-ID1
 Serial Number: 101420003111
 Firmware Version: 1.10b73

CHANNEL INFO
 Type: DO/OPDO/Pressure
 Serial Number: 000105
 Firmware: 1.00

GLP DATA 1
 Calibration point 1: 0.0 % Sat
 Date/Time: 2024-06-09 09:10:54
 DO Value: 0.0 % Sat
 Pressure: 749.4 mmHg

MOD3 DO

- Tap **Share** to export a report. Prior configuration is required.
 - USB inserts into socket.
 - Print
 - FTP
 - Email

Deleting a Batch from Meter

The **HI6000** can save a maximum of 20 BOD batches. Each batch can up to contain 200 samples. To allow analysis of newer batches, delete older batches.

- Tap **Start BOD**.

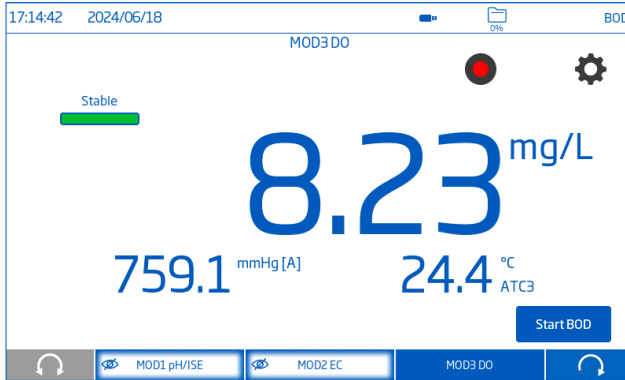

- Tap **Info** or **Edit** of selected batch.

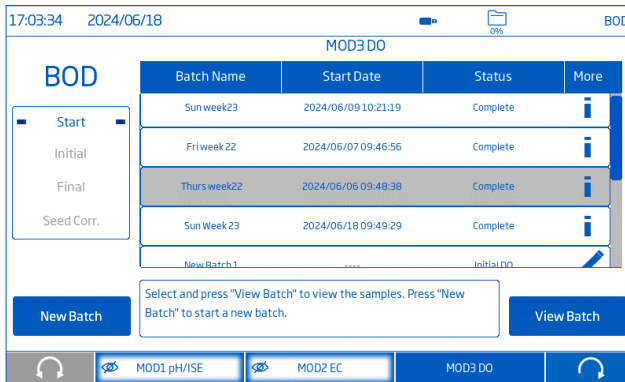

- Tap **Delete**. Batch will be removed from meter but Report will still be available.

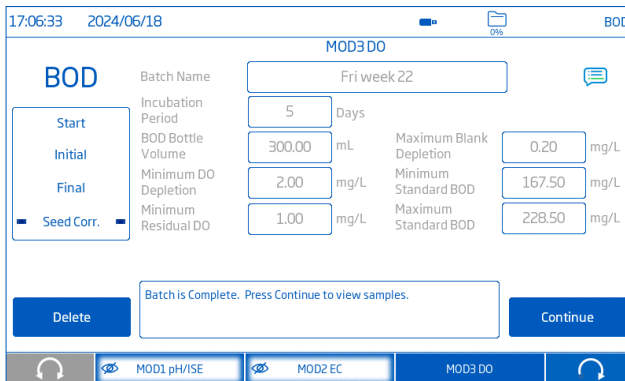

- Confirm deletion.

16. MAINTENANCE

16.1. METER

The following steps outline the process to ensure users keep the meter clean and disinfected while limiting the risk of damage from unsuitable cleaners.

- Disinfect the screen using commercially available, non-ammonia glass or disinfectant cleaner.
- Apply a small amount of cleaner directly to a microfiber or lint-free disposable cloth. Make sure the cloth is damp and not wet.
- Wipe the glass touchscreen clean with the cloth. Do not apply cleaner directly to the interface.

16.2. HI1131B pH ELECTRODE

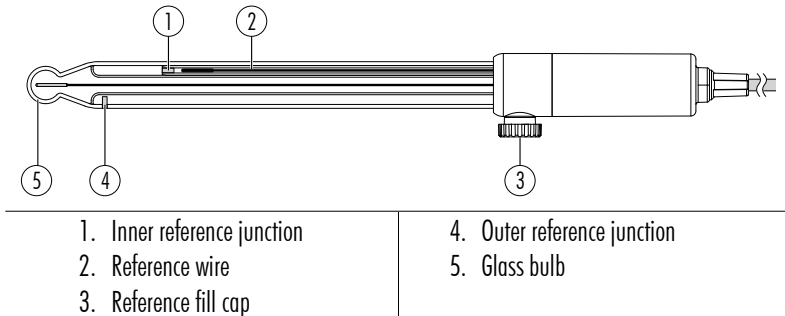

Electrode Maintenance

- Soak the pH bulb and reference junction in [HI70300 Storage Solution](#) for a minimum of 30 minutes to refresh the electrode (before calibration).
- Calibrate the electrode after prolonged storage or cleaning.
- After use, rinse the electrode with purified water and blot excess moisture with a lint free tissue.
- Inspect all sensor connectors for corrosion and replace if necessary.

pH Sensor Maintenance

- Remove the sensor protective cap. Do not be alarmed if any salt deposits are present. This is normal with pH / ORP probes and they will disappear when rinsed with water.
- Shake the probe down gently to eliminate any trapped air bubbles.
- If the bulb and/or junction are dry, soak the electrode in [HI70300 Storage solution](#) for at least 30 minutes.
- To ensure a quick response, the glass bulb and the junction should be kept moist and not allowed to dry. This can be achieved by storing the sensor with a few drops of [HI70300 Storage solution](#) or pH 4.01 in the protective cap.

Note: Never use distilled or deionized water to store the electrode.

Periodic Maintenance

- Inspect the electrode for any scratches or cracks. If any are present, replace the electrode.
- Inspect the cable. The connection cable must be intact.
- Rinse off any salt deposits with water.

pH Cleaning Procedure

1. Soak the sensor in [HI7061](#) Electrode cleaning solution for general use or application-specific cleaning solution for 15 minutes.
2. Rinse with water.
3. Soak the electrode in [HI70300](#) Storage solution for at least 30 minutes, rinse with water and calibrate before using.

Protein, Inorganic, Oil, or Grease Cleaning Procedure

1. Soak the sensor in application-specific electrode cleaning solution (e.g. [HI7073](#) Protein cleaning, [HI7074](#) Inorganic cleaning for 15 minutes or [HI7077](#) Oil and Fat cleaning solution).
2. Rinse the sensor with water.

Note: After performing any of the cleaning procedures, rinse the electrode thoroughly with water and soak in [HI70300](#) Storage solution for at least 30 minutes before calibrating it.

3. Soak the electrode in [HI70300](#) Storage solution for at least 1 hour, rinse with water, and calibrate before using.

16.3. HI7662-TW TEMPERATURE PROBE

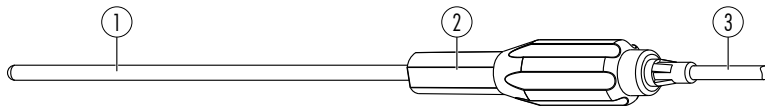

1. Stainless steel tube
2. Handle
3. Cable

16.4. HI7631233 EC AND RESISTIVITY PROBE

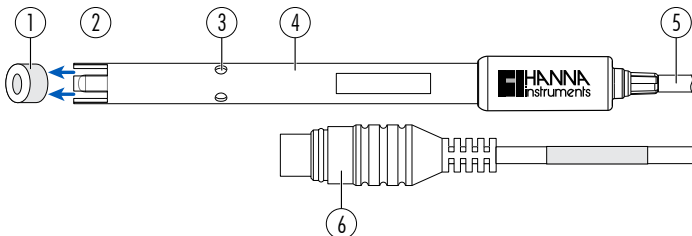

- | | |
|--|------------------|
| 1. Plastic bung (remove for measurement and calibration) | 4. Probe body |
| 2. Probe sensor | 5. Cable |
| 3. Probe holes | 6. DIN connector |

Maintenance

Rinse the probe thoroughly as water residue may not be visible.

Cleaning

Dirty or improperly cleaned probes can result in erratic and inaccurate readings.

- Clean off the external sheath with a soft cloth and surfactant solution.
- Rinse the probe under a stream of running tap water to remove salt or minerals. Jet the tap water stream through the opening to dislodge any debris.
- Only if strictly necessary, carefully remove the outer plastic sheath to disassemble the probe. Clean off with a warm water (surfactant) mixture and follow with a through rinsing with purified water. Allow pieces to dry and reassemble.

Calibrate the probe with the appropriate standard solution for the intended application.

Storage

- Store the probe dry, after cleaning in distilled water.
- Clean the probe and calibrate after long-term storage.

16.5. HI7641133 OPDO® PROBE

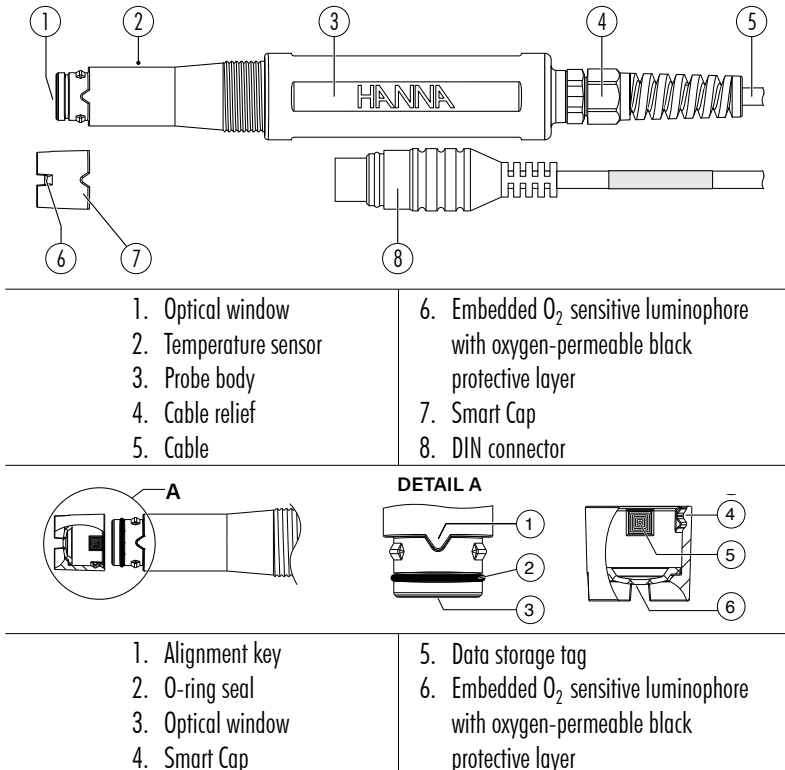

General Maintenance

- Inspect O-ring for nicks or other damage. Replacing the O-ring is advised.
- Do not substitute other grease or lubricants as it may cause the O-ring to swell.
- After long-term storage or cleaning, calibrate the probe.
- After use, rinse the probe with tap water and dry it.
- The DO cap must be kept hydrated.

Cleaning the Smart Cap

- Use a mild detergent and a soft-bristled toothbrush to clean.
- Rinse with water after cleaning and dry with a laboratory tissue.
- Hydrate in purified water before use.

Note: Smart Caps need to be replaced every year.

Smart Cap Replacement

One year after a new cap installation, the message “opdo[®] Cap Expired” is displayed. To maintain measurement accuracy, the Smart Cap replacement is mandatory.

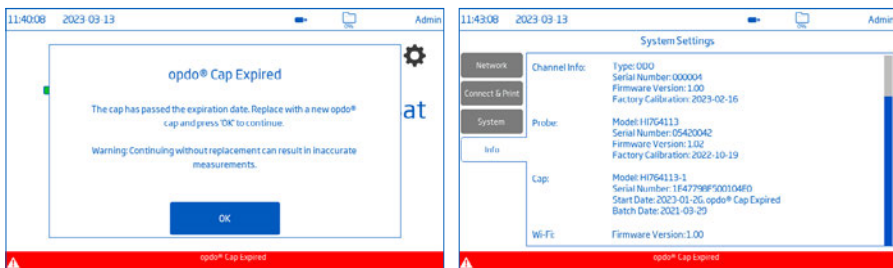

Probe Replacement Cap Kit

The probe replacement cap kit contains:

- Smart Cap for opdo probe (1 piece)
- sachet with silicone grease (6 g)
- syringe (1 piece)
- lens wipe (1 piece)
- certification / instruction sheet (1 piece)

Smart Cap Replacement Procedure

1. Turn off the meter and unplug the probe.

Note: Verify time and date are properly set on the meter, prior to new cap initialization.

2. Clean off the probe body and dry off with cloth.

3. Remove the expired Smart Cap from the probe by squeezing the cap at the cutout arrow and pulling it off the probe body. Do not twist the cap!

4. Remove the used O-ring by rolling it off the body.

5. Clean the O-ring groove and lens with a soft tissue followed by the lens cleaning wipe.

6. Remove the new O-ring from container and slide it on the probe tip (do not roll or twist the O-ring).

7. Use a syringe filled with silicone grease and sparingly lubricate the O-ring with a thin film of grease. Avoid getting grease or fingerprints onto the optical window.

8. Remove the new optical cap from its container and align the cutout arrow on the Smart Cap with the matching guide on the probe body.

9. Slide and press the Smart Cap onto the probe body until the cap snaps in place. Once the cap is installed, it should not be removed unless a new cap is required.



10. Place the probe in purified water to hydrate the Smart Cap before use for a minimum of 2 hours.

11. Connect the probe DIN connector to the meter DIN socket.

12. Power the meter to initiate the cap timer.

13. Calibrate.

16.6. HI764833 DO POLAROGRAPHIC PROBE

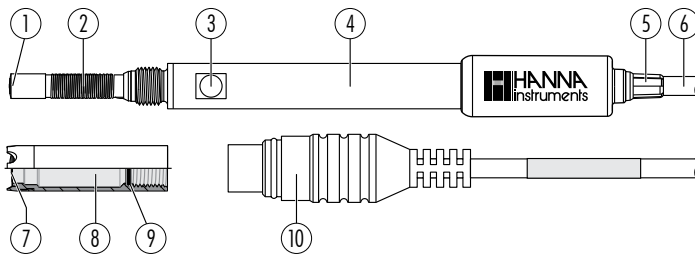

1. Glass insulator/platinum cathode

2. Ag/AgCl anode and reference

3. Temperature sensor

4. Probe body

5. Cable relief

6. Cable

7. Oxygen permeable PTFE membrane

8. Screw cap

9. O-ring seal

10. DIN connector

General Maintenance

- Inspect membrane surface to ensure it is in good condition.
- Rinse carefully with distilled or deionized water to clean.
- Damaged membranes need to be replaced.
- Verify no bubbles are trapped between the cathode and membrane.

Cathode Cleaning

1. Remove cap and inspect platinum cathode is bright and untarnished. If tarnished, clean with a clean lint-free cardboard or cloth. Gently polish off any stains.
2. Rinse the probe with deionized or distilled water.
3. Install a new membrane cap using fresh electrolyte.

Note: Use care when handling the probe tip.

Inspect that the insulator has not been cracked.

Membrane Cap Replacement

New probe: unscrew the shipping cap and save.

Probe in use: unscrew the old cap.

1. Take one O-ring and one membrane cap and position the O-ring (1) in the cap (2).
2. Rinse the membrane cap with electrolyte and discard.
3. Fill the cap, above the O-ring, with electrolyte and tap the side walls to dislodge bubbles that may adhere to the threads.
4. Over a sink, with the cathode facing down, screw the cap counter clockwise until the threads are fully engaged.
5. Rinse the probe and inspect the membrane for trapped bubbles. If any, discard the electrolyte, refill, and tap the sides. Reinstall.

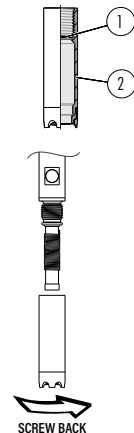

Storage

Store with protective cap on.

Conditioning

Before proceeding with the calibration make sure the probe is ready for measurements.

1. Reinstall the plastic protective cap over membrane end.
2. Reconnect probe to meter and allow probe to polarize.

17. SOFTWARE UPDATE

To introduce new features and/or performance improvements Hanna Instruments® releases updated firmware versions. To check for new releases, scan the QR code or go to: <https://software.hannainst.com>.



Requirements

- USB-A drive (FAT32 format)

Steps

1. Scroll down the software downloads page to find the **Instrument Firmware** list.
2. Connect the USB-A flash drive to PC.
3. Find the Firmware Version needed for download, then click **DOWNLOAD NOW**.
4. Wait for *.hiup file download to complete.
5. Copy file to flash drive.
6. Plug the flash drive into the USB-A port and turn the meter on.



7. Wait for update to complete.

Update will take about 1 hour to complete. During this time do not turn off the meter or disconnect the power.



8. Once the update is complete the meter will cycle power automatically.
9. Turn off the meter and remove the flash drive.
10. Turn on the meter.

18. ERROR MESSAGES

The system gives warning messages:

- when erroneous conditions appear
- while logging
- when measured values are outside the expected range
- for invalid high/low temperature alarm value
- invalid low/high mV Alarm value, isopotential point

Note: See notifications area at the bottom of the screen.

The information below provides an explanation of the errors and warnings, and recommended action to be taken.

18.1. pH, ORP, ISE

Displayed Message	Explanation & Recommended Action
Temperature under/over range	Temperature outside specified range. Verify the temperature probe is correctly connected to the meter. Replace probe if necessary.
Under/over compensation range	During pH calibration, the temperature is under/over the pH buffer compensation limit.
pH under/over range	Occurs when apparent pH value is less than -2.0 pH (or more) than 20.0 pH. Soak electrode in HI70300 Storage solution for at least 30 minutes.
pH out of calibration range	Displayed when the measured value is outside calibration range.
Rel. mV offset under/over range Rel. mV under/over range	Outside range in the corresponding scale.
ISE under/over range	Occurs when apparent ISE concentration is outside specified range.
ISE out of calibration range	Displayed when the measured value is outside calibration range.
Factory calibration expired	Contact the Hanna technical support for the periodic factory calibration.

18.2. CONDUCTIVITY

Displayed Message	Explanation & Recommended Action
Temperature under/over range	Temperature outside specified range. Replace probe if necessary.
Under/over compensation range	During conductivity calibration, the temperature is under/over the conductivity calibration solution compensation limit.
EC under/over range	Outside range in the corresponding scale. Ensure the vent holes are completely submerged and the sample is within specified range.

Displayed Message	Explanation & Recommended Action
EC out of calibration range	Displayed when the measured value is outside calibration range.
Resistivity under/over range	Resistivity outside specified range. Ensure the sample is within specified range.
TDS under/over range	TDS outside specified range. Ensure the sample is within specified range.
Salinity under/over range	Salinity outside specified range. Ensure the sample is within specified range.
Factory calibration expired	Contact the Hanna technical support for the periodic factory calibration.

18.3. DISSOLVED OXYGEN

Displayed Message	Explanation & Recommended Action
DO % over range	Reading is over specified measurement range: <ul style="list-style-type: none"> • Optical probe <ul style="list-style-type: none"> ◦ above 500 % / 90 ppm (mg/L) • Polarographic probe <ul style="list-style-type: none"> ◦ above 300 % / 45 ppm (mg/L) Ensure the sample is within specified range.
Temperature under / over range	Temperature outside specified range: <ul style="list-style-type: none"> • Optical probe <ul style="list-style-type: none"> ◦ below $-5\text{ }^{\circ}\text{C}$ ($23\text{ }^{\circ}\text{F}$) / above $50\text{ }^{\circ}\text{C}$ ($122\text{ }^{\circ}\text{F}$) • Polarographic probe <ul style="list-style-type: none"> ◦ below $0\text{ }^{\circ}\text{C}$ ($32\text{ }^{\circ}\text{F}$) / above $50\text{ }^{\circ}\text{C}$ ($122\text{ }^{\circ}\text{F}$) for Consider probe replacement if necessary.
Pressure under / over range	Below 450.0 mmHg / above 850.0 mmHg (or equivalent)
User calibration expired	Calibrate the meter.
opdo [®] Cap Expired	Replace the cap.
Factory calibration expired	Contact the Hanna technical support for the periodic factory calibration.

18.4. PROBE & TEMPERATURE SENSOR

Broken electrode	The meter fails to calibrate or gives faulty readings. Replace the probe.
Temperature sensor broken	Replace the sensor

19. ACCESSORIES

pH Buffer Calibration Solutions

HI6016	Millesimal calibration buffer pH 1.679 (500 mL)
HI6003	Millesimal calibration buffer pH 3.000 (500 mL)
HI6004	Millesimal calibration buffer pH 4.010 (500 mL)
HI6068	Millesimal calibration buffer pH 6.862 (500 mL)
HI6007	Millesimal calibration buffer pH 7.010 (500 mL)
HI6010	Millesimal calibration buffer pH 10.010 (500 mL)
HI6124	Millesimal calibration buffer pH 12.450 (500 mL)
HI8004L	Buffer solution pH 4.01 (500 mL, FDA approved bottle)
HI8006L	Buffer solution pH 6.86 (500 mL, FDA approved bottle)
HI8007L	Buffer solution pH 7.01 (500 mL, FDA approved bottle)
HI8009L	Buffer solution pH 9.18 (500 mL, FDA approved bottle)
HI8010L	Buffer solution pH 10.01 (500 mL, FDA approved bottle)

Conductivity Solutions

HI7030M or HI7030L	12880 $\mu\text{S}/\text{cm}$ standard solution, 250 or 500 mL
HI7031M or HI7031L	1413 $\mu\text{S}/\text{cm}$ standard solution, 230 or 500 mL
HI7033M or HI7033L	84 $\mu\text{S}/\text{cm}$ standard solution, 230 or 500 mL
HI7034M or HI7034L	80000 $\mu\text{S}/\text{cm}$ standard solution, 250 or 500 mL
HI7035M or HI7035L	111800 $\mu\text{S}/\text{cm}$ standard solution, 230 or 500 mL
HI7037M or HI7037L	100 % NaCl seawater salinity standard solution, 250 or 500 mL
HI7039M or HI7039L	5000 $\mu\text{S}/\text{cm}$ standard solution, 250 or 500 mL

Dissolved Oxygen Solutions

HI7040L	Zero oxygen solution set, 500 mL + 12 g
HI7041S	Refilling electrolyte solution, 30 mL

Electrode Electrolyte Refill Solutions

HI7071	3.5M KCl + AgCl Electrolyte for single junction electrodes, 4 pcs. (30 mL)
HI7072	1M KNO ₃ Electrolyte, 4 pcs. (30 mL)
HI7082	3.5M KCl Electrolyte for double junction electrodes, 4 pcs. (30 mL)
HI8071	3.5M KCl + AgCl Electrolyte for single junction electrodes, 4 pcs. (30 mL, FDA approved bottle)
HI8072	1M KNO ₃ Electrolyte, 4 pcs. (30 mL, FDA approved bottle)
HI8082	3.5M KCl Electrolyte for double junction electrodes, 4 pcs. (30 mL, FDA approved bottle)
HI8093	1M KCl + AgCl Electrolyte, 4 pcs. (30 mL, FDA approved bottle)

Electrode Storage Solutions

HI70300L	Storage solution (500 mL)
HI80300L	Storage solution (500 mL, FDA approved bottle)

Electrode Cleaning Solutions

HI70000P	Electrode rinse sachet, 25 pcs. (20 mL)
HI7061L	General purpose solution (500 mL)
HI7073L	Protein cleaning solution (500 mL)
HI7074L	Inorganic substance cleaning solution (500 mL)
HI7077L	Oil and Fat cleaning solution (500 mL)
HI8061L	General purpose solution (500 mL, FDA approved bottle)
HI8073L	Protein cleaning solution (500 mL, FDA approved bottle)
HI8077L	Oil and fat cleaning solution (500 mL, FDA approved bottle)

Other Accessories

HI740036P	100 mL beaker (10 pcs.)
HI764080A/P	Spare membranes (5 pcs.)
HI764113-1	DO Smart Cap with O-ring
HI764113-2	Calibration / storage vessel
HI764060	Electrode holder
HI900946	115 Vac to 24 Vdc power adapter, US plug
HI900947	230 Vac to 24 Vdc power adapter, European plug
HI920016	USB type A to C cable

Electrodes

Electrode part numbers ending in **B** are supplied with a BNC connector and 1 m (3.3') cable.

Electrode part numbers ending in **Y** are supplied with a BNC + RCA connector.





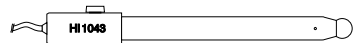



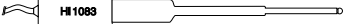

pH

HI1043B Glass body, double junction, refillable, combination electrode
Application: strong acid or alkali

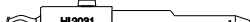

HI1053B Glass body, triple ceramic, conical shape, refillable, combination electrode
Application: suited for emulsions

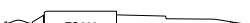

HI1083B	Glass body, micro diameter, viscolene, non refillable, combination electrode Application: biotechnology, micro titration	
HI1131B	Glass body, refillable, double junction, combination electrode Application: general purpose	
HI1330B	Glass body, semi-micro diameter, single junction, refillable, combination electrode Application: laboratory, vials	
HI1331B	Glass body, semi-micro diameter, single junction, refillable, combination electrode Application: suited for flasks	
HI1230B	Plastic body (PEI), double junction, gel filled, combination electrode Application: general, field	
HI2031B	Glass body, semi-micro diameter, conical, single junction, refillable, combination electrode Application: semisolids	
HI1332B	Plastic body (PEI), double junction, refillable, combination electrode Application: general purpose	
HI1413B	Glass body, single junction, flat tip, viscolene, non refillable, combination electrode Application: surface measurement	
FC100B	Plastic body (PVDF), double junction, refillable, combination electrode Application: general purpose for food industry	
FC200B	Plastic body (PVDF), single junction, conical, viscolene, non refillable, combination electrode Application: meat and cheese	
FC210B	Glass body, double junction, conical, viscolene, non refillable, combination electrode Application: milk and yogurt	
FC220B	Glass body, triple ceramic, single junction, refillable, combination electrode Application: food processing	

pH with 10K NTC thermistor

HI1131Y Glass body, single ceramic frit, double junction, refillable, combination electrode
Application: general purpose

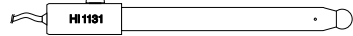

HI1230Y PEI body, single ceramic frit, double junction, combination electrode
Application: general purpose



HI1048Y Glass body, CPS sleeve junction, combination electrode
Application: wine, must, juice

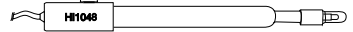

ORP

HI3131B Glass body, refillable, combination platinum electrode, ORP sensing pin
Application: titration

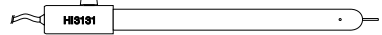

HI3230B Plastic body (PEI), gel filled, combination platinum electrode, ORP sensing pin
Application: general purpose



HI4430B Plastic body (PEI), gel filled, combination gold electrode, ORP sensing pin
Application: general purpose



Extension cables for screw-type electrodes (screw to BNC adapter)



HI7855/1, 1 m (3.3') long

HI7855/3, 3 m (9.9') long

Note: Please refer to the Hanna Instruments® general catalog for more electrodes with screw-type or BNC connectors.

CERTIFICATION

All Hanna® instruments conform to the CE European Directives.



Disposal of Electrical & Electronic Equipment. The product should not be treated as household waste. Instead hand it over to the appropriate collection point for the recycling of electrical and electronic equipment which will conserve natural resources.

Ensuring proper product disposal prevents potential negative consequences for the environment and human health. For more information, contact your city, your local household waste disposal service, or the place of purchase.

RECOMMENDATIONS FOR USERS

Before using this product, make sure it is entirely suitable for your specific application and for the environment in which it is used. Any variation introduced by the user to the supplied equipment may degrade the meter's performance. For yours and the meter's safety do not use or store the meter in hazardous environments.

WARRANTY

HI6000 is warranted for two years against defects in workmanship and materials when used for its intended purpose and maintained according to instructions. Electrodes and probes are warranted for a period of six months. This warranty is limited to repair or replacement free of charge. Damage due to accidents, misuse, tampering or lack of prescribed maintenance is not covered.

If service is required, contact your local Hanna Instruments office. If under warranty, report the model number, date of purchase, serial number (see engraved on the bottom of the meter) and the nature of the problem. If the repair is not covered by the warranty, you will be notified of the charges incurred. If the meter is to be returned to Hanna Instruments, first obtain a Returned Goods Authorization number from the Technical Service department and then send it with shipping costs prepaid. When shipping any meter, make sure it is properly packed for complete protection.

REGULATORY NOTICES FOR THE WI-FI MODULE

United States (FCC) FCC ID: 2ADHKATWINC1500.

This device complies with Part 15 of the FCC Rules. Operation is subject to the following two conditions: (1) this device may not cause harmful interference, and (2) this device must accept any interference received, including interference that may cause undesired operation.

Canada (ISED) IC: 20266-WINC1500PB

HVIN: ATWINC1500-MR210PB

PMN: ATWINC1500-MR210PB

This device complies with Industry Canada's license exempt RSS standard(s). Operation is subject to the following two conditions: (1) This device may not cause interference, and (2) This device must accept any interference, including interference that may cause undesired operation of the device. Le présent appareil est conforme aux CNR d'Industrie Canada applicables aux appareils radio exempts de licence. L'exploitation est autorisée aux deux conditions suivantes: (1) l'appareil ne doit pas produire de brouillage, et (2) l'utilisateur de l'appareil doit accepter tout brouillage radioélectrique subi, même si le brouillage est susceptible d'en compromettre le fonctionnement.

Under Industry Canada regulations, this radio transmitter may only operate using an antenna of a type and maximum (or lesser) gain approved for the transmitter by Industry Canada. To reduce potential radio interference to other users, the antenna type and its gain should be so chosen that the equivalent isotropically radiated power (e.i.r.p.) is not more than that necessary for successful communication. Conformément à la réglementation d'Industrie Canada, le présent émetteur radio peut fonctionner avec une antenne d'un type et d'un gain maximal (ou inférieur) approuvé pour l'émetteur par Industrie Canada. Dans le but de réduire les risques de brouillage radioélectrique à l'intention des autres utilisateurs, il faut choisir le type d'antenne et son gain de sorte que la puissance isotrope rayonnée équivalente (p.i.r.e.) ne dépasse pas l'intensité nécessaire à l'établissement d'une communication satisfaisante.

Japan (MIC) 005-101762

South Korea (KCC) R-CRM-mcp-WINC1510MR210P

Taiwan (NCC) CCAN18LP0321T2

注意！依據 低功率電波輻射性電機管理辦法 第十二條 經型式認證合格之低功率射頻電機，非經許可，公司、商號或使用者均不得擅自變更頻率、加大功率或變更原設計之特性及功能。第十四條 低功率射頻電機之使用不得影響飛航安全及干擾合法通信；經發現有干擾現象時，應立即停用，並改善至無干擾時方得繼續使用。前項合法通信，指依電信規定作業之無線電信。低功率射頻電機須忍受合法通信或工業、科學及醫療用 電波輻射性 電機設備之干擾。

China (SRRC) CMIIT ID: 2018DJ1305

ANATEL 08497-18-08759

Note: FCC information is marked on the back of the device.